

ITEM NO.	PART NUMBER	DESCRIPTION	QTY.
1	PHMS.25-1	1/4-20 X 1" PAN HEAD MACH. SCREW	1
2	8002R-000	TRAFFIC CHANNEL SS CABLE CLIP	1
3	8002R-120	CHANNEL SS CABLE CLIP	1

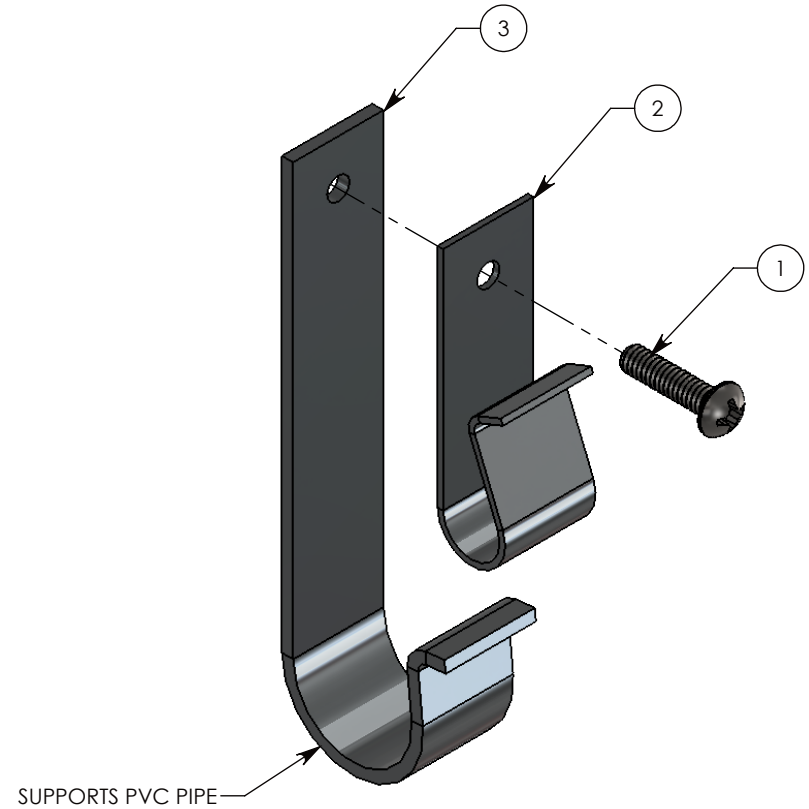

**NOTE 1:** MACHINE SCREW IS INCLUDED  
**NOTE 2:** TRAFFIC RATED CHANNELS HAVE CAST-IN THREADED INSERTS FOR MOUNTING CABLE CLIPS.

<b>DRAWN BY: ROBIN FLINT</b>	
<b>DATE: 1/28/2017</b>	<b>REVISION LEVEL: A</b>
<b>WEIGHT: 0.4 LBS.</b>	<b>MATERIAL: NOTED</b>

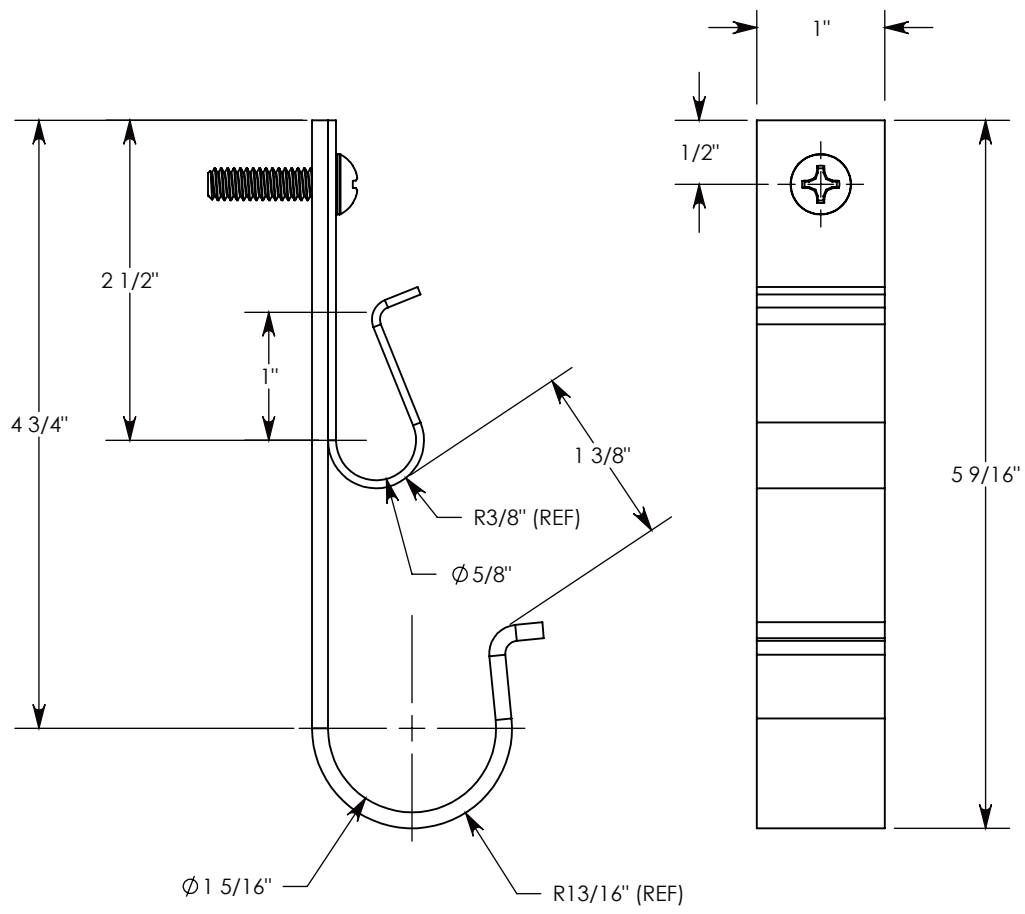

1010 NORTH STAR DRIVE  
P.O. BOX 69  
ZUMBROTA, MN 55992-0069

<b>DESCRIPTION:</b> <b>TRAFFIC RATED CHANNEL DOUBLE CABLE CLIP</b>		
DIMENSIONS ARE IN INCHES TOLERANCES: FRACTIONAL: ± 1/8" ANGULAR: ± 2°	CONTACT INFORMATION: EMAIL: INFO@CONCASTINC.COM PHONE: (507) 732-4095 FAX: (507) 732-4094	SHEET 1 OF 3
<b>PART NUMBER:</b> <b>8002R-012</b>		