

REV. A - SIC - 10/16/2019 - 1/2"-13 UNC LIFTING INSERT QTY: 4, WAS QTY: 3  
 REV. B - SIC - 6/29/2020 - UPDATED ANNOTATIONS; UPDATED WEIGHT RATING TO MAX H-40, WAS H-20; ADDED SOIL BEARING PRESSURES

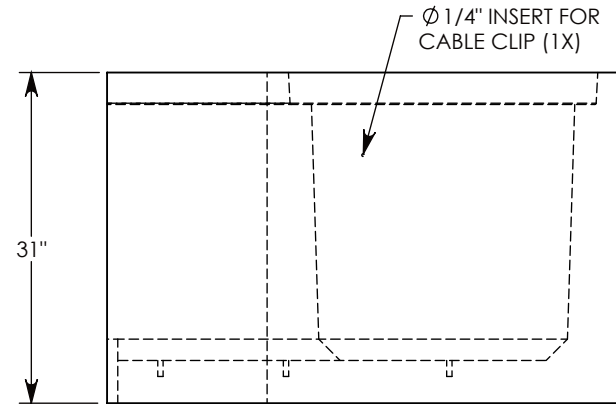
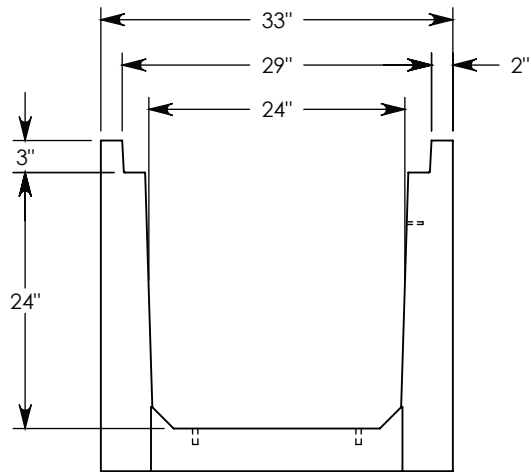
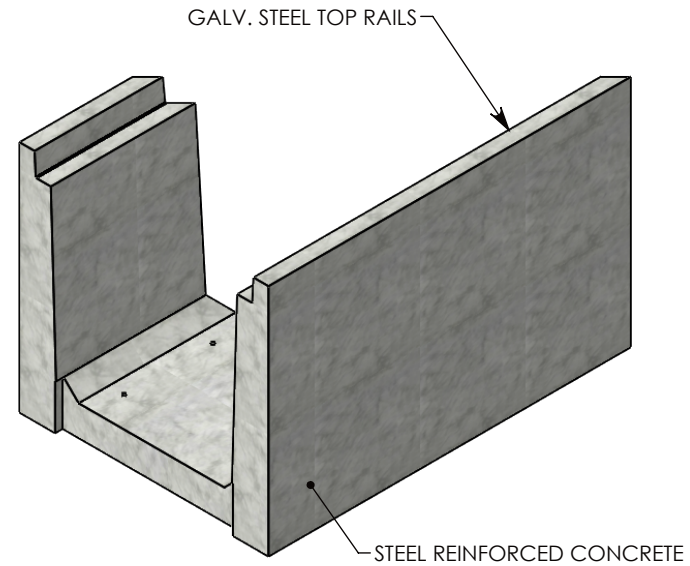
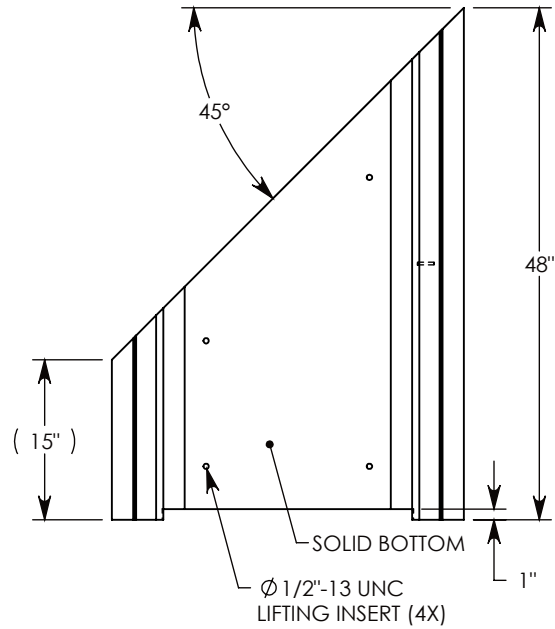

MAX AASHTO H-40 RATED - 64,000 LB. SINGLE AXLE LOAD  
 DEPENDENT ON TRENCH COVER RATING  
 MINIMUM ALLOWABLE SOIL BEARING PRESSURE - H-40: 3,500 PSF; H-20: 3,000 PSF

**DRAWN BY: ROBIN FLINT**

**CREATED DATE: 3/21/2011**    **REVISION LEVEL: B**

**SAVED DATE: 6/29/2020**    **SAVED BY: scallahan**

**WEIGHT: 936 LBS.**    **MATERIAL: CONCRETE**

**CONCAST**  
 1010 NORTH STAR DRIVE  
 P.O. BOX 69  
 ZUMBROTA, MN 55992-0069

**DESCRIPTION:**  
**HT CHANNEL; 45 DEG. ANGLE**

DIMENSIONS ARE IN INCHES  
 TOLERANCES:  
 FRACTIONAL: ± 1/8"  
 ANGULAR: ± 2°

CONTACT INFORMATION:  
 EMAIL: INFO@CONCASTINC.COM  
 PHONE: (507) 732-4095  
 FAX: (507) 732-4094

SHEET 1 OF 1

**PART NUMBER:**  
**802424HT3 45L**