

REV A. - TCJ - 7/2/2018 - UPDATED RATING FROM H-20 TO H-40
 REV B. - SIC - 2/4/2020 - UPDATED RATING FROM H-40 TO MAX H-40; LIFTING INSERT QTY: 4, WAS QTY: 3
 REV C. - SIC - 7/21/2020 - UPDATED WEIGHT RATING NOTE; ADDED SOIL BEARING PRESSURES

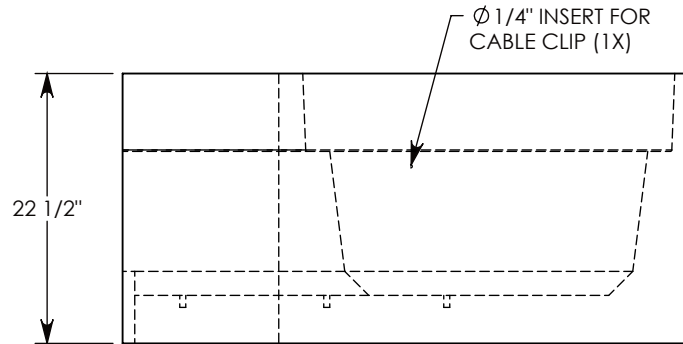
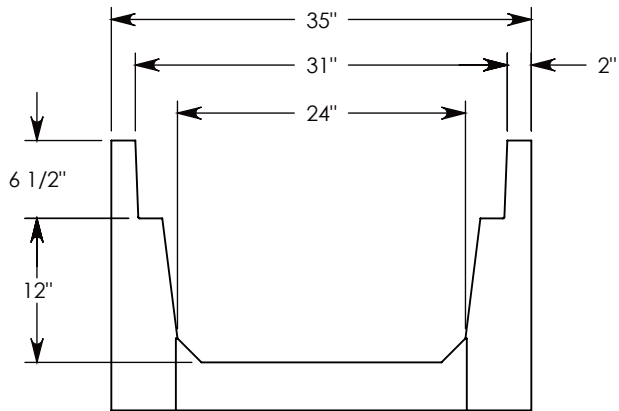
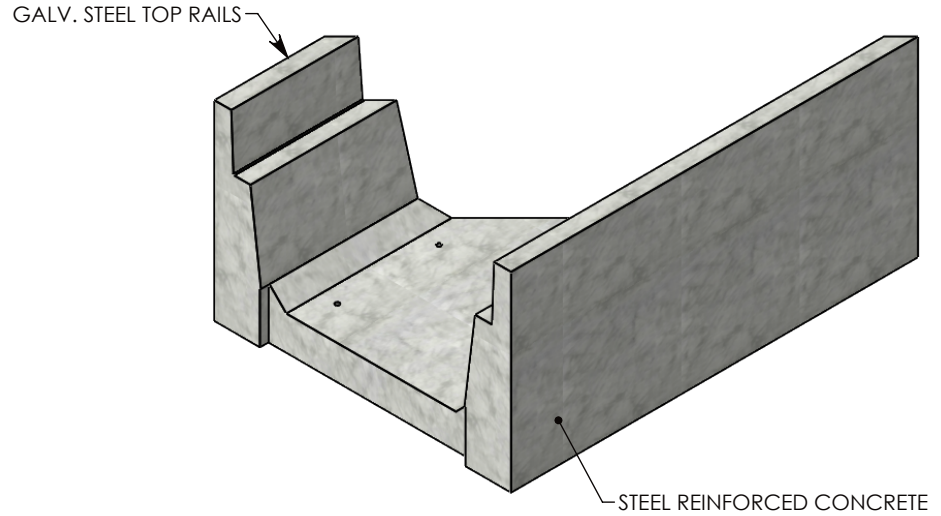
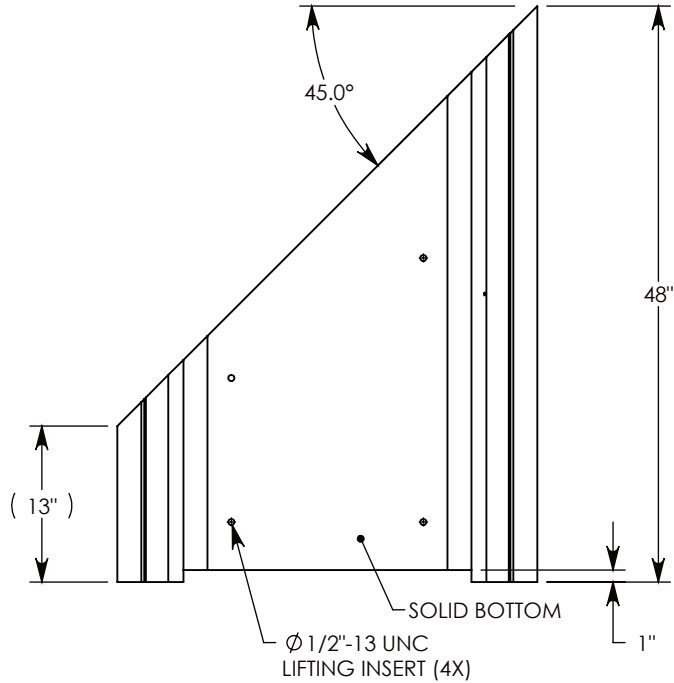

MAX AASHTO H-40 RATED - 64,000 LB. SINGLE AXLE LOAD
 DEPENDENT ON TRENCH COVER RATING
 MINIMUM ALLOWABLE SOIL BEARING PRESSURE - H-40: 3,500 PSF; H-20: 3,000 PSF

DRAWN BY: ROBIN FLINT	
CREATED DATE: 3/21/2011	REVISION LEVEL: C
SAVED DATE: 7/21/2020	SAVED BY: scallahan
WEIGHT: 719 LBS.	MATERIAL: CONCRETE

1010 NORTH STAR DRIVE
 P.O. BOX 69
 ZUMBROTA, MN 55992-0069

DESCRIPTION:		SHEET 1 OF 1
HT CHANNEL; 45 DEG. ANGLE		
DIMENSIONS ARE IN INCHES	CONTACT INFORMATION:	
TOLERANCES:	EMAIL: INFO@CONCASTINC.COM	
FRACTIONAL: ± 1/8" ANGULAR: ± 2°	PHONE: (507) 732-4095 FAX: (507) 732-4094	
PART NUMBER:		
8024HT 45L		