

REV. A - SIC - 8/19/2019 - UPDATED ANNOTATIONS, DIMENSIONS, AND VIEWS; UPDATED LIFTING INSERT LAYOUT
 REV. B - SIC - 7/17/2020 - UPDATED WEIGHT RATING TO MAX H-40, WAS H-20; ADDED SOIL BEARING PRESSURES

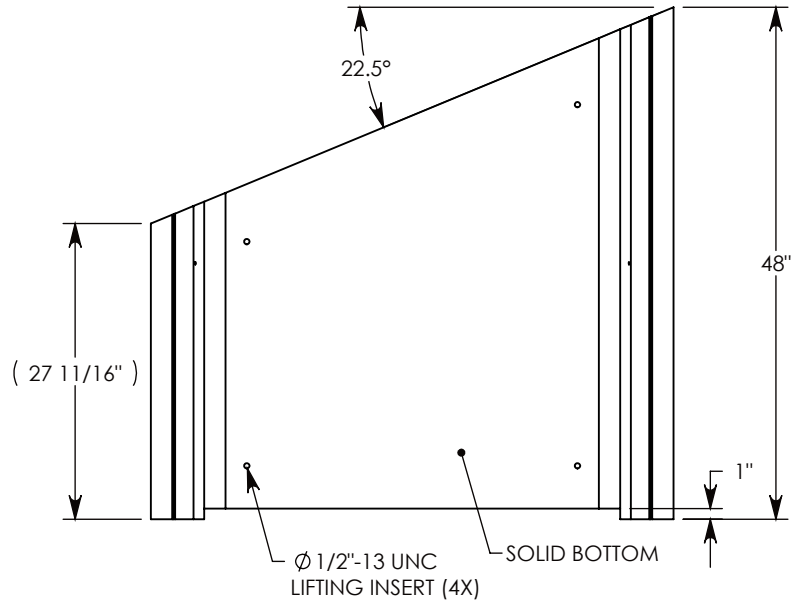

GALV. STEEL TOP RAILS

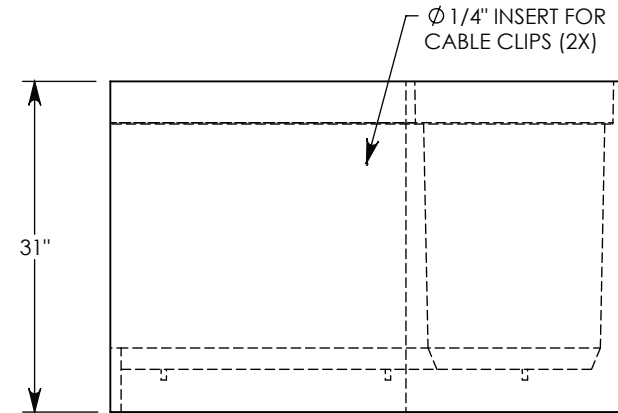
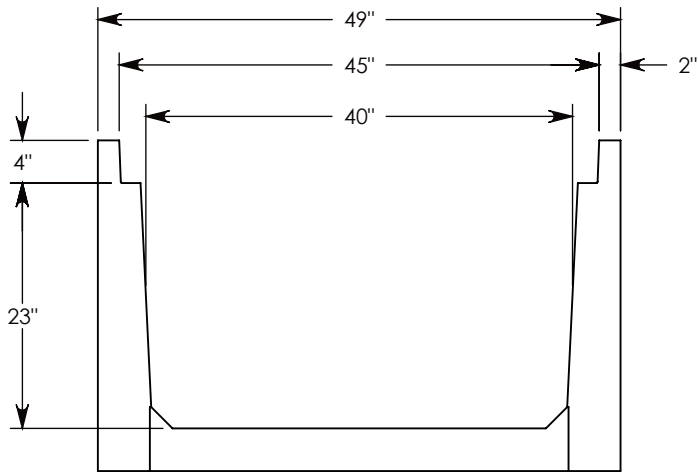
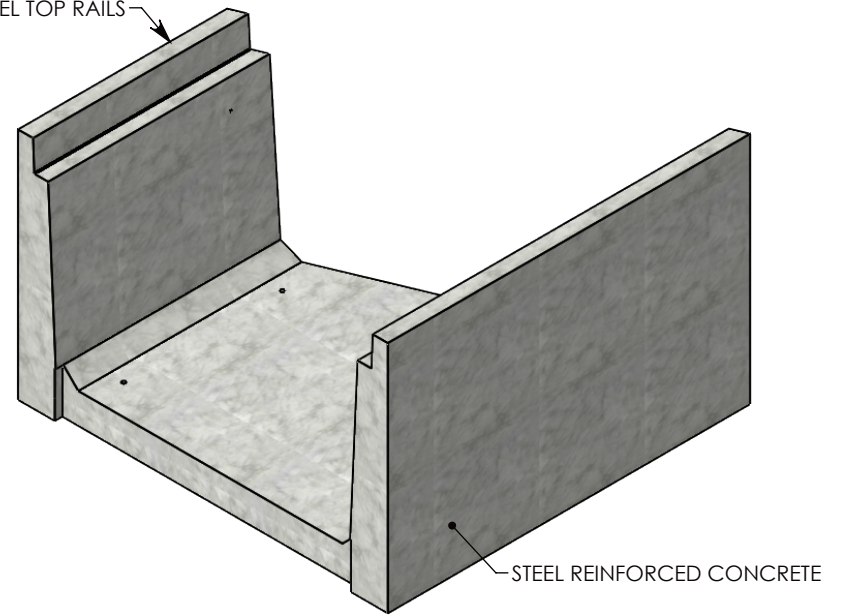

MAX AASHTO H-40 RATED - 64,000 LB. SINGLE AXLE LOAD
 DEPENDENT ON TRENCH COVER RATING
 MINIMUM ALLOWABLE SOIL BEARING PRESSURE - H-40: 3,000 PSF; H-20: 3,000 PSF

DRAWN BY: ROBIN FLINT	
CREATED DATE: 3/21/2011	REVISION LEVEL: B
SAVED DATE: 7/17/2020	SAVED BY: scallahan
WEIGHT: 1306 LBS.	MATERIAL: CONCRETE



1010 NORTH STAR DRIVE
 P.O. BOX 69
 ZUMBROTA, MN 55992-0069

DESCRIPTION: HT CHANNEL; 22.5 DEG. ANGLE		SHEET 1 OF 1
DIMENSIONS ARE IN INCHES TOLERANCES: FRACTIONAL: ± 1/8" ANGULAR: ± 2°	CONTACT INFORMATION: EMAIL: INFO@CONCASTINC.COM PHONE: (507) 732-4095 FAX: (507) 732-4094	
PART NUMBER: 804024HT4 22.5L		