

REVISION A - RLF - 6/7/16 - 1" INTERLOCK RELIEF WAS A 7/8" PROTRUSION.

**FIBERCRETE<sup>®</sup>**  
**TRENCH SYSTEM**

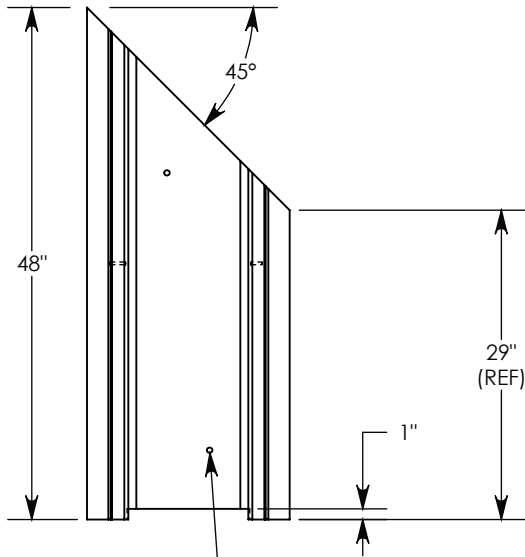

Ø 1/2"-13 UNC INSERTS  
 (2X) FOR LIFTING

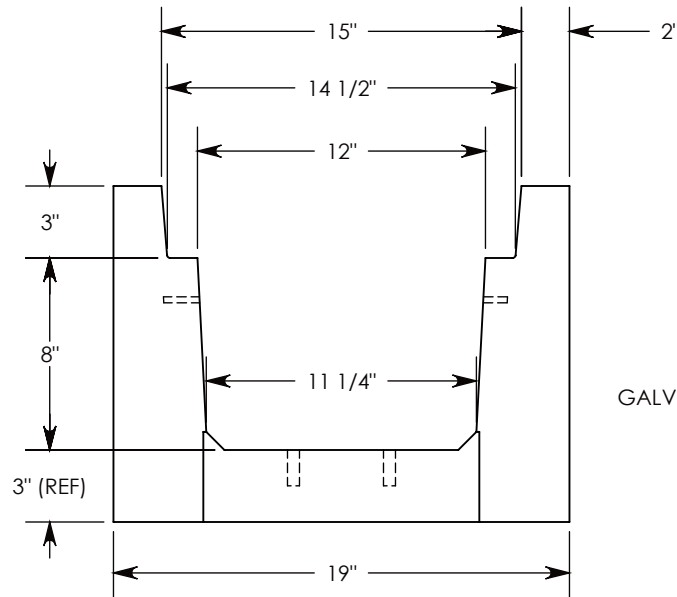

**DETAIL A**  
**SCALE 1 : 8**

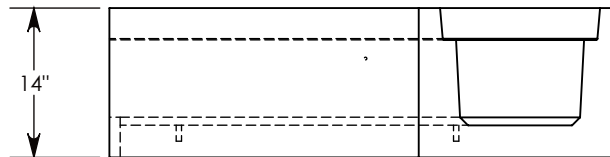
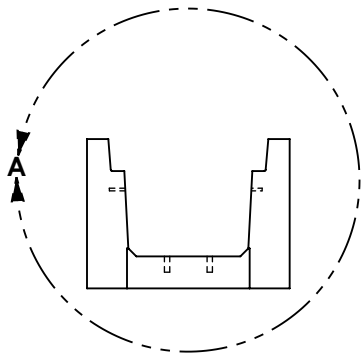
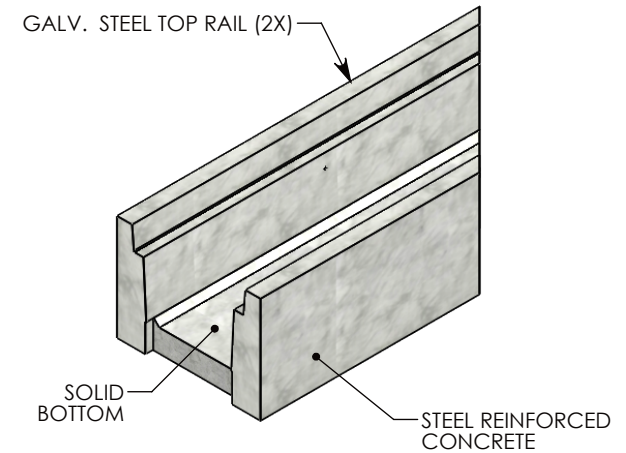

**NOTE 1:** MMR#30032973

H-20 RATED - 32,000 LB. PER AXLE LOAD

**DRAWN BY:** ROBIN FLINT

**DATE:** 6/7/2016

**REVISION LEVEL:** A

**WEIGHT:**

**406 LBS.**

**MATERIAL:**

**CONCRETE**

1010 NORTH STAR DRIVE  
 P.O. BOX 69  
 ZUMBROTA, MN 55992-0069

**DESCRIPTION:**  
**HEAVY TRAFFIC CHANNEL - 45 ANGLE**

DIMENSIONS ARE IN INCHES  
 TOLERANCES:  
 FRACTIONAL: ± 1/8"  
 ANGULAR: ± 2°

CONTACT INFORMATION:  
 EMAIL: INFO@CONCASTINC.COM  
 PHONE: (507) 732-4095  
 FAX: (507) 732-4094

SHEET 1 OF 1

**PART NUMBER:**  
**HT1208 45R**