

Ø 1/2"-13 UNC INSERT (4X) FOR PULLING EYES. LOCATED ON BOX INTERIOR (1X PER SIDE)

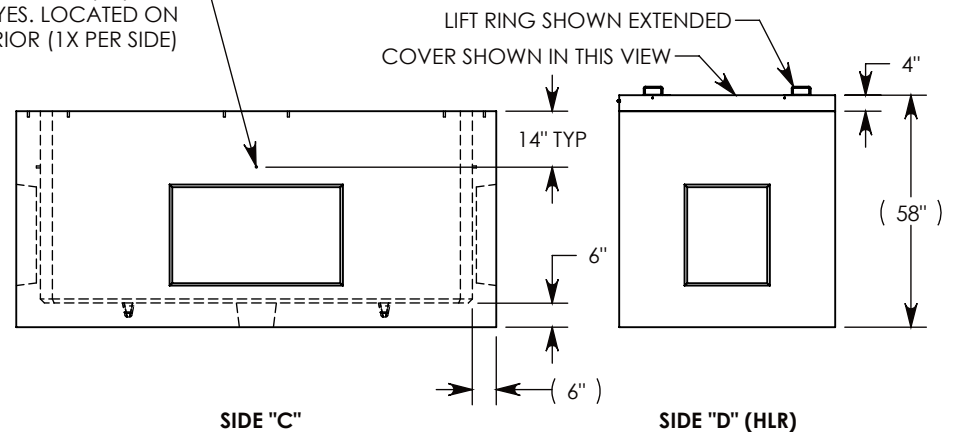
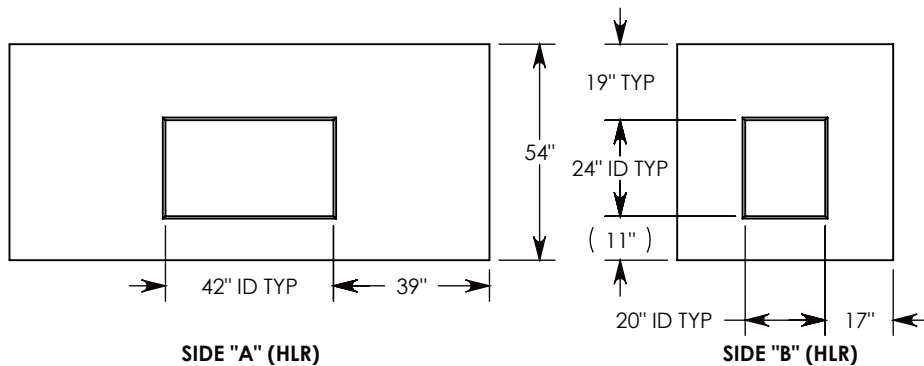

NOTE 1: FOR ADDED SECURITY, PENTA HEAD (P/N: PTA.38-2.5) OR SURELOCK BOLT (P/N: SL.38-2.5) CAN BE ADDED

AASHTO H-10 RATED - 16,000 LB. SINGLE AXLE LOAD

DRAWN BY: <b>SAMUEL CALLAHAN</b>	
DATE: <b>7/16/2019</b>	REVISION LEVEL: <b>0</b>
WEIGHT: <b>9990 LBS.</b>	MATERIAL: <b>NOTED</b>

1010 NORTH STAR DRIVE  
P.O. BOX 69  
ZUMBROTA, MN 55992-0069

<b>DESCRIPTION:</b> <b>CONCRETE PULL BOX W/ HALT COVER</b>		SHEET 1 OF 1
DIMENSIONS ARE IN INCHES TOLERANCES: FRACTIONAL: ± 1/8" ANGULAR: ± 2°	CONTACT INFORMATION: EMAIL: INFO@CONCASTINC.COM PHONE: (507) 732-4095 FAX: (507) 732-4094	
<b>PART NUMBER:</b> <b>PBK01-54-120-54-HALT</b>		