



CONCAST

Fibercrete®

PRECISELY ENGINEERED HIGH STRENGTH CONCRETE



GENERATOR PADS

FIBERCRETE® LIGHTWEIGHT GENERATOR FLAT PAD PART NO.	SOLID CONCRETE GENERATOR FLAT PAD PART NO.	PAD LENGTH "L"	PAD WIDTH "W"	PAD HEIGHT "H"
FC-24-36-4	FPS-24-36-4	24"	36"	4"
FC-36-48-4	FPS-36-48-4	36"	48"	4"
FC-36-60-4	FPS-36-60-4	36"	60"	4"
FC-36-72-4	FPS-36-72-4	36"	72"	4"
FC-48-72-4	FPS-48-72-4	48"	72"	4"
FC-48-96-4	FPS-48-96-4	48"	96"	4"

FLAT PAD OPTIONS:

- Hold-down clamps
- Threaded inserts
- Unistrut Channel
- Toggle Nuts
- Custom Holes/Openings
- Wedge Anchors

These flat pads are specifically designed to support stand-by generators. Mounting hardware can be purchased from Concast for your pad so that holes can be precisely located and field-drilled for easy installation of the cabinet via it's bolt pattern.

Pads are available in both the lightweight FC series and the solid FPS series. If you need a different size flat pad than what is listed, Concast can create custom pads to accommodate your equipment requirements. See the www.concastinc.com/flat_pads/applications/generator/ for pad details.

Concast is continually working to find new precast solutions that will supply our customers with the best line of concrete products in a timely manner, while still upholding our high quality standards. Concast stands behind our products with an unmatched 35 year warranty.

LIGHTWEIGHT "FC" FLAT PADS

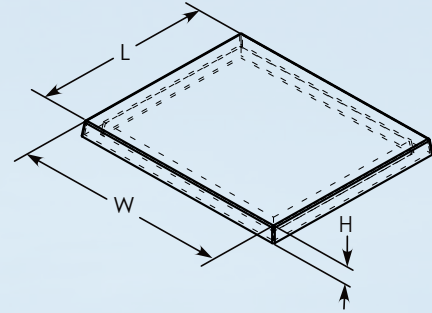

- The very lightest pad we manufacture.
- Most sizes can be installed without the aid of mechanical maneuvering equipment.
- Toggle nuts are recommended for mounting.

SOLID "FPS" FLAT PADS

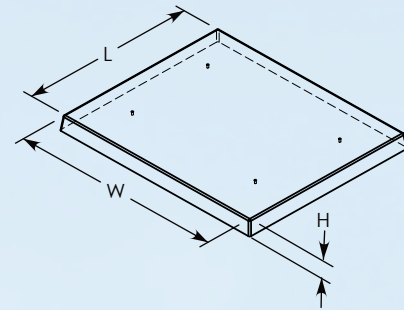

- The most economical Concast pad.
- Ideal where pad weight is not an issue.
- Perfect for wet soil condition installations.
- Wedge anchors are recommended for mounting.



P.O. Box 69
1010 North Star Drive
Zumbrota, MN 55992-0069

