

REV. A - SIC - 8/23/2019 - ADDED CABLE CLIP INSERTS; UPDATED VIEWS AND ANNOTATIONS

REV. B - SIC - 10/7/2020 - ADDED TOP RAIL REDUCTION FEATURE TO CHANGE TOP RAIL TO 2", WAS 3"; REPLACED RIGHT VIEW WITH SECTION A-A; ADDED DETAIL B; REVISED CSTT DESIGN; ADDED WEIGHT

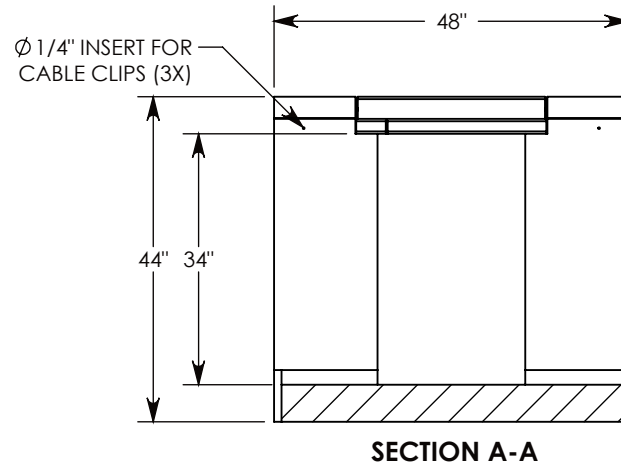
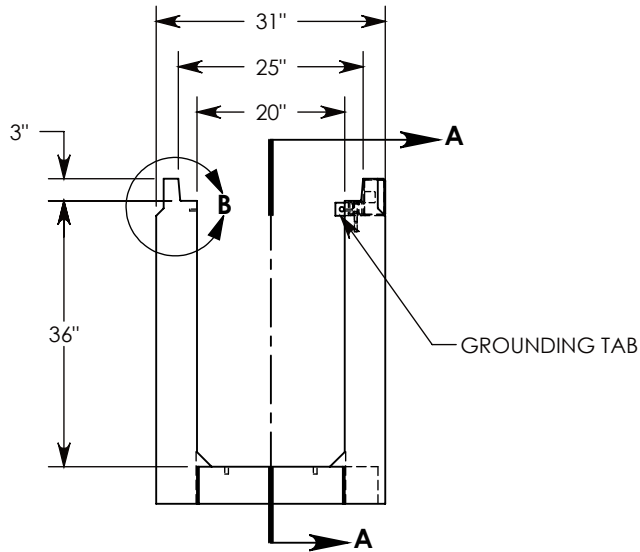
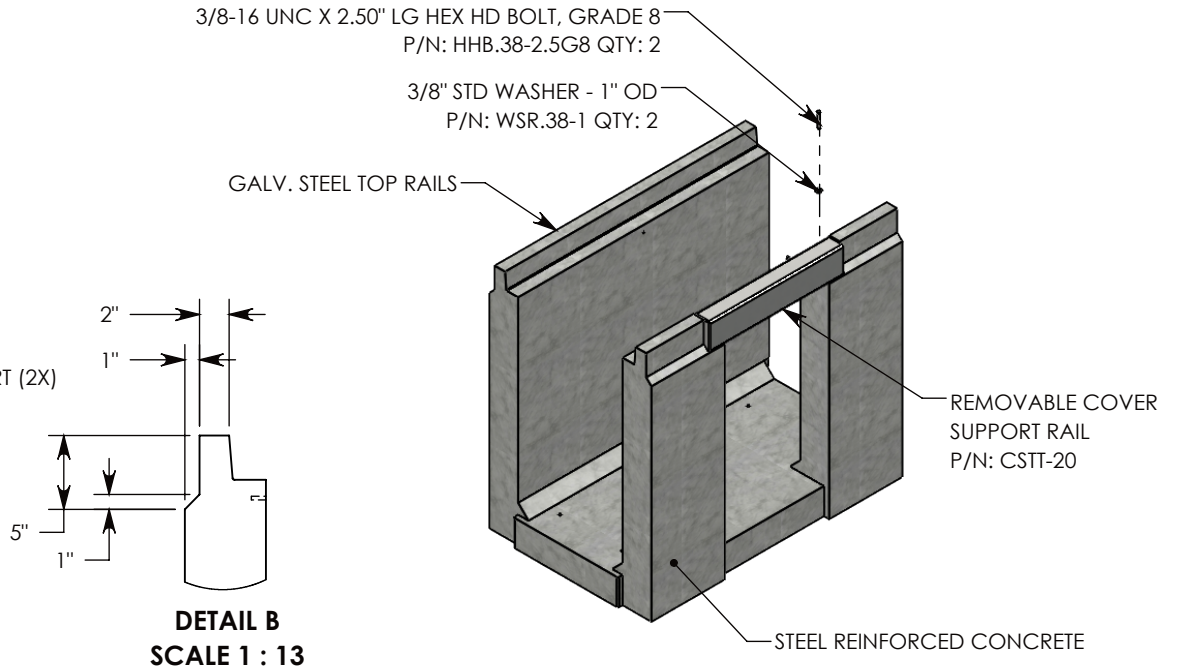
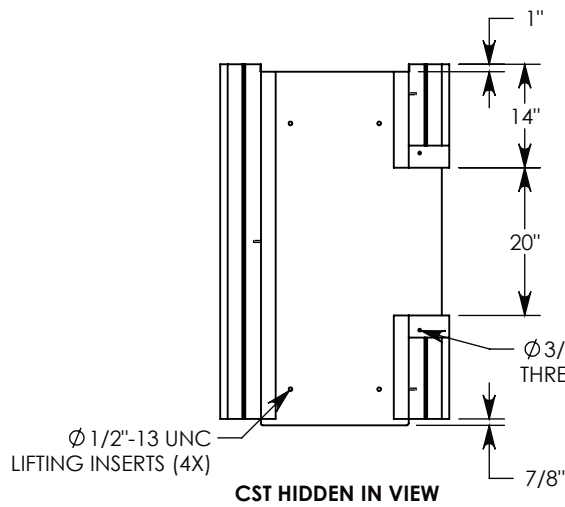

AASHTO H-20 RATED - 32,000 LB. SINGLE AXLE LOAD

DRAWN BY: ROSS LAGER

CREATED DATE: 1/17/2019 **REVISION LEVEL:** B

SAVED DATE: 10/7/2020 **SAVED BY:** scallahan

WEIGHT: 1898 LBS. **MATERIAL:** NOTED

 1010 NORTH STAR DRIVE
 P.O. BOX 69
 ZUMBROTA, MN 55992-0069

DESCRIPTION:
HEAVY TRAFFIC UNIVERSAL

DIMENSIONS ARE IN INCHES
 TOLERANCES:
 FRACTIONAL: $\pm 1/8"$
 ANGULAR: $\pm 2^\circ$

CONTACT INFORMATION:
 EMAIL: INFO@CONCASTINC.COM
 PHONE: (507) 732-4095
 FAX: (507) 732-4094

SHEET 1 OF 1

PART NUMBER:
802236HT3 (20X0)