

REV. A - SIC - 8/23/2019 - ADDED CABLE CLIP INSERTS; UPDATED VIEWS AND ANNOTATIONS

REV. B - SIC - 10/7/2020 - ADDED TOP RAIL REDUCTION FEATURE TO CHANGE TOP RAIL TO 2", WAS 3"; REPLACED RIGHT VIEW WITH SECTION A-A; ADDED DETAIL B; REVISED CSTT DESIGN; ADDED WEIGHT

3/8-16 UNC X 2.50" LG HEX HD BOLT, GRADE 8  
P/N: HHB.38-2.5G8 QTY: 4

3/8" STD WASHER - 1" OD  
P/N: WSR.38-1 QTY: 4

REMOVABLE COVER  
SUPPORT RAIL  
P/N: CSTT-20

GALV. STEEL TOP RAILS

REMOVABLE COVER  
SUPPORT RAIL  
P/N: CSTT-20

GROUNDING TAB

STEEL REINFORCED CONCRETE

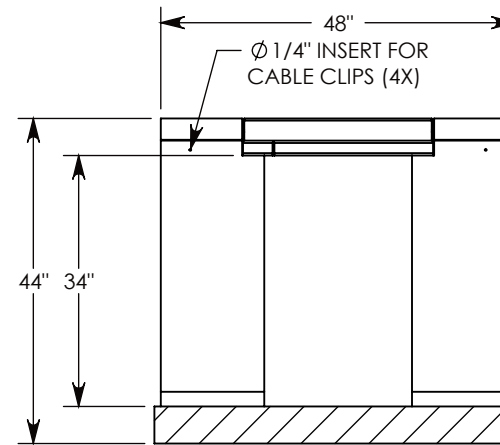
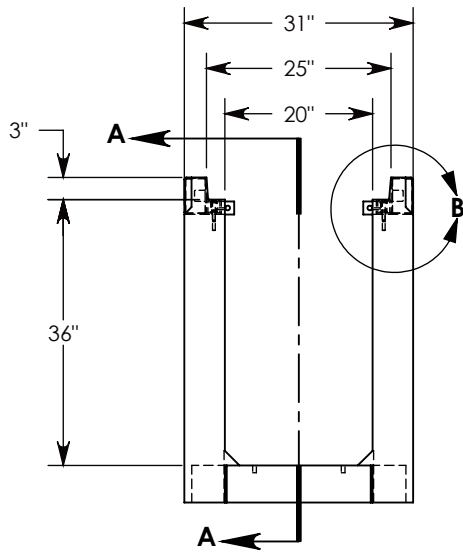
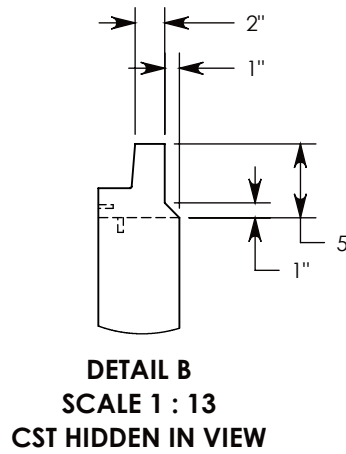
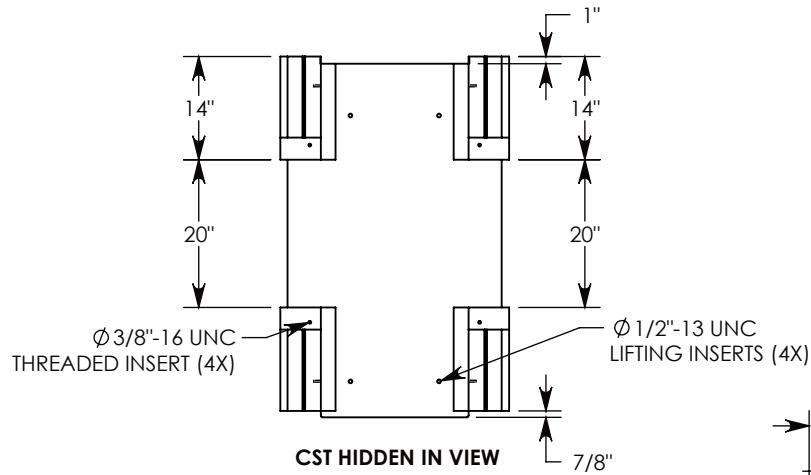

SECTION A-A

AASHTO H-20 RATED - 32,000 LB. SINGLE AXLE LOAD

**DRAWN BY:** ROSS LAGER

**CREATED DATE:** 1/17/2019 **REVISION LEVEL:** B

**SAVED DATE:** 10/7/2020 **SAVED BY:** scallahan

**WEIGHT:** 1577 LBS. **MATERIAL:** NOTED

1010 NORTH STAR DRIVE  
P.O. BOX 69  
ZUMBROTA, MN 55992-0069

**DESCRIPTION:**  
**HEAVY TRAFFIC UNIVERSAL**

DIMENSIONS ARE IN INCHES  
TOLERANCES:  
FRACTIONAL: ± 1/8"  
ANGULAR: ± 2°

CONTACT INFORMATION:  
EMAIL: INFO@CONCASTINC.COM  
PHONE: (507) 732-4095  
FAX: (507) 732-4094

SHEET 1 OF 1

**PART NUMBER:**  
**802236HT3 (20X20)**