

REV. A - SIC - 8/20/2019 - REMOVED NOTE 1; UPDATED ANNOTATIONS

REV. B - SIC - 10/6/2020 - ADDED TOP RAIL REDUCTION FEATURE TO CHANGE TOP RAIL TO 2", WAS 3"; REPLACED RIGHT VIEW WITH SECTION A-A; ADDED DETAIL B

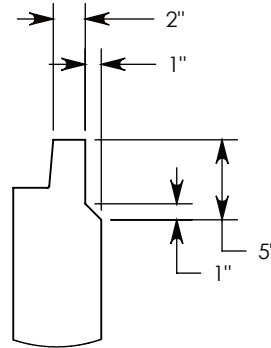

**DETAIL B**  
SCALE 1 : 12

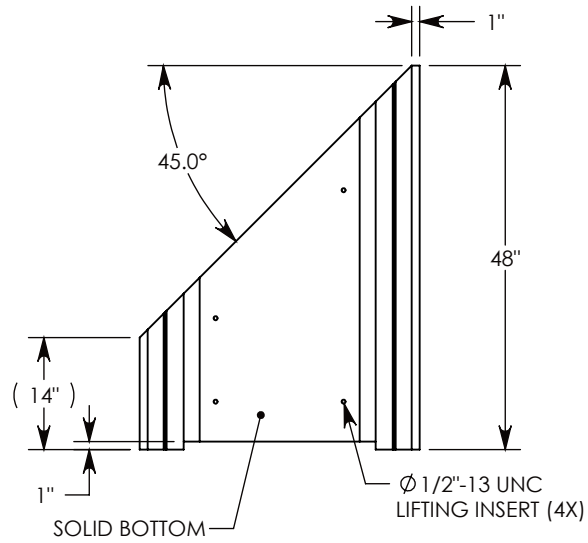
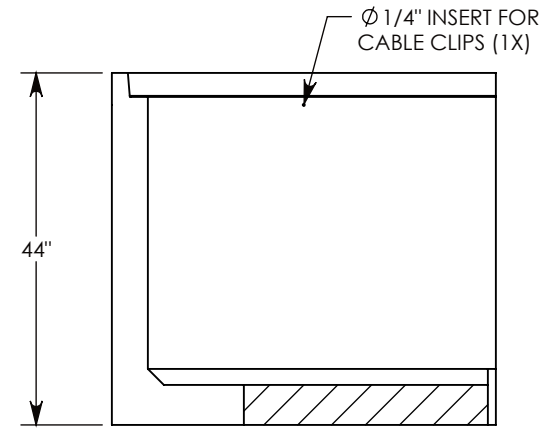
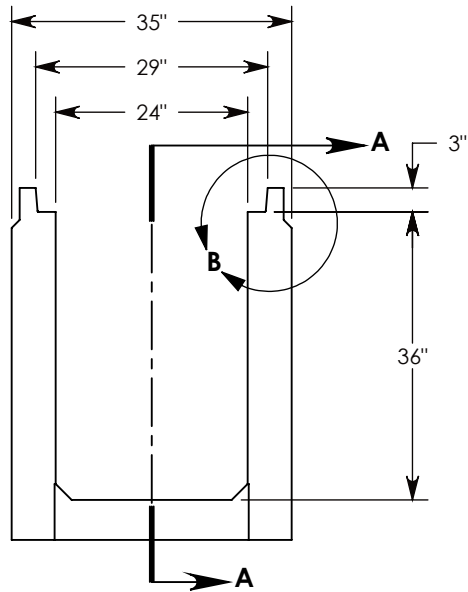
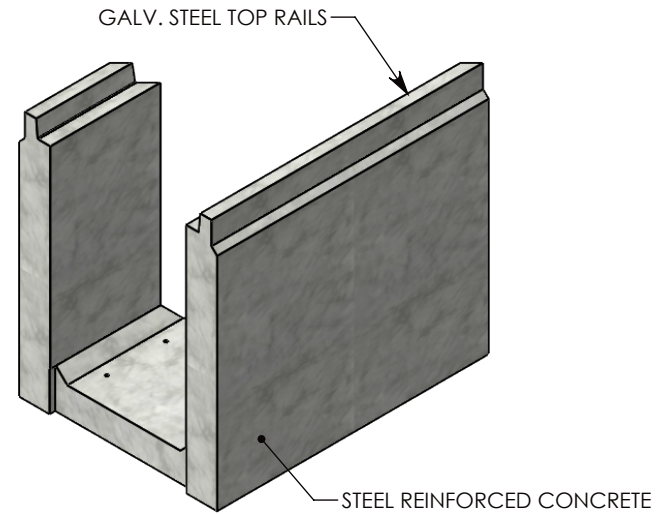

**SECTION A-A**

AASHTO H-20 RATED – 32,000 LB. SINGLE AXLE LOAD

**DRAWN BY: ROSS LAGER**

**CREATED DATE: 1/18/2019**    **REVISION LEVEL: B**

**SAVED DATE: 10/6/2020**    **SAVED BY: scallahan**

**WEIGHT: 1497 LBS.**    **MATERIAL: CONCRETE**



**CONCAST**  
1010 NORTH STAR DRIVE  
P.O. BOX 69  
ZUMBROTA, MN 55992-0069

**DESCRIPTION:**  
**HEAVY TRAFFIC CHANNEL**

DIMENSIONS ARE IN INCHES  
TOLERANCES:  
FRACTIONAL: ± 1/8"  
ANGULAR: ± 2°

CONTACT INFORMATION:  
EMAIL: INFO@CONCASTINC.COM  
PHONE: (507) 732-4095  
FAX: (507) 732-4094

SHEET 1 OF 1

**PART NUMBER:**  
**802436HT3 45L**