

REV. A - SIC - 10/17/2019 - 1/2"-13 UNC LIFTING INSERT QTY: 4, WAS QTY: 2  
 REV. B - SIC - 6/29/2020 - UPDATED ANNOTATIONS; UPDATED WEIGHT RATING TO MAX H-40, WAS H-20; ADDED SOIL BEARING PRESSURES

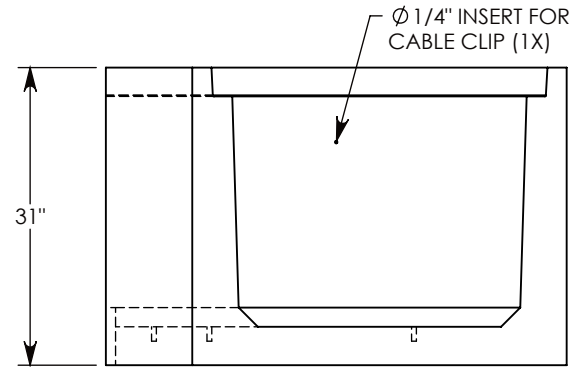

MAX AASHTO H-40 RATED - 64,000 LB. SINGLE AXLE LOAD  
 DEPENDENT ON TRENCH COVER RATING  
 MINIMUM ALLOWABLE SOIL BEARING PRESSURE - H-40: 3,000 PSF; H-20: 3,000 PSF

<b>DRAWN BY: ROBIN FLINT</b>	
<b>CREATED DATE: 3/21/2011</b>	<b>REVISION LEVEL: B</b>
<b>SAVED DATE: 6/29/2020</b>	<b>SAVED BY: scallahan</b>
<b>WEIGHT: 900 LBS.</b>	<b>MATERIAL: CONCRETE</b>

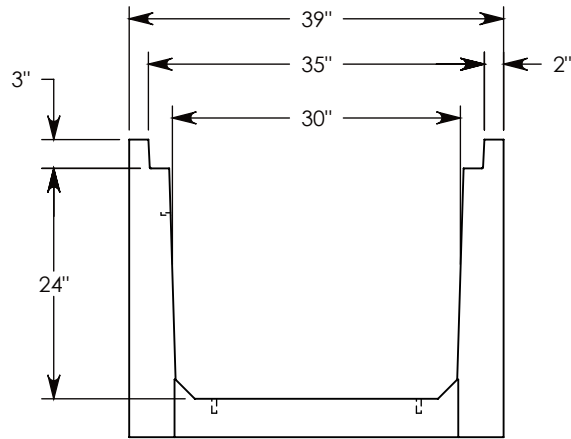
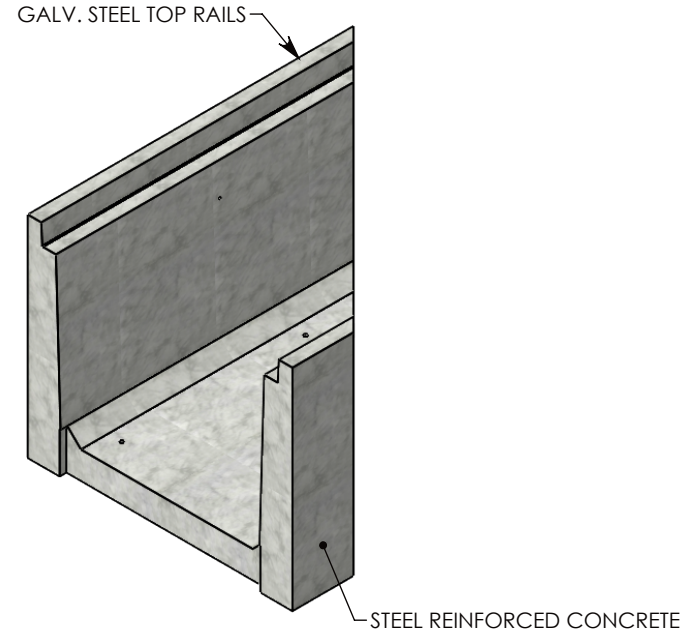
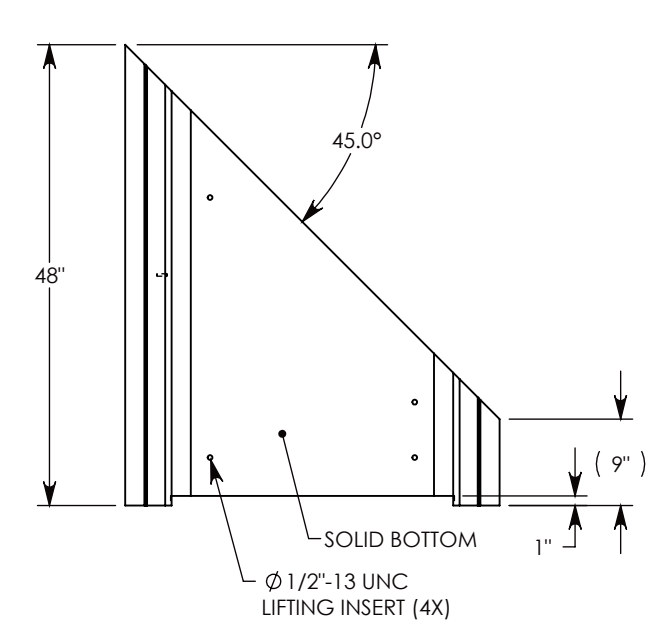

**CONCAST**  
 1010 NORTH STAR DRIVE  
 P.O. BOX 69  
 ZUMBROTA, MN 55992-0069

<b>DESCRIPTION:</b>		SHEET 1 OF 1
<b>HT CHANNEL; 45 DEG. ANGLE</b>		
DIMENSIONS ARE IN INCHES	CONTACT INFORMATION:	
TOLERANCES:	EMAIL: INFO@CONCASTINC.COM	
FRACTIONAL: ± 1/8"	PHONE: (507) 732-4095	
ANGULAR: ± 2°	FAX: (507) 732-4094	
<b>PART NUMBER:</b>		
<b>803024HT3 45R</b>		