

REV. A - JCG - 12/19/2017 - INCREASED WIDTH AND INCREASED DRAFT
 REV. B - JCG - 1/15/2018 - ADDED RECESS & THRU HOLE
 REV. C - SIC - 2/9/2024 - UPDATED TITLEBLOCK; MOVED INSERTS IN TO 6", WAS 4"; REMOVED FIBERCRETE LOGO

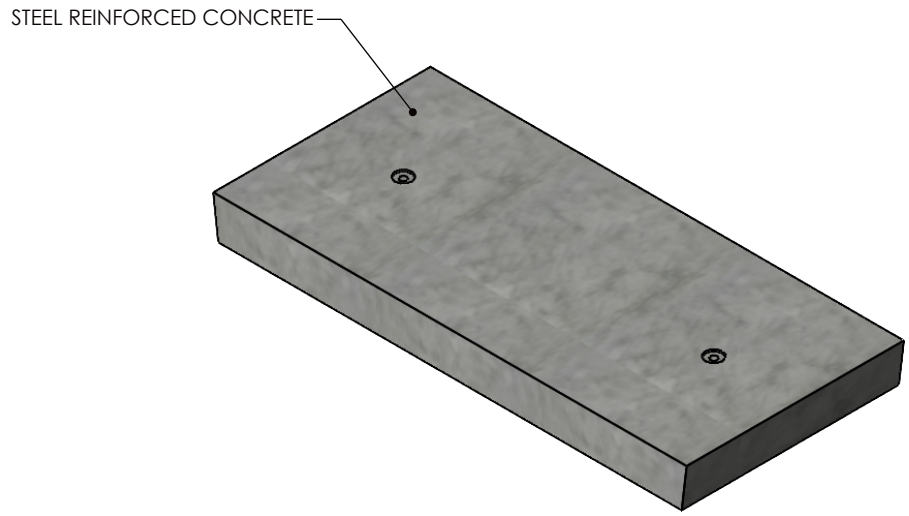

COVER ASSEMBLES ONTO 30" INSIDE WIDTH
 HEAVY TRAFFIC RATED CONCAST HT3 CHANNEL.

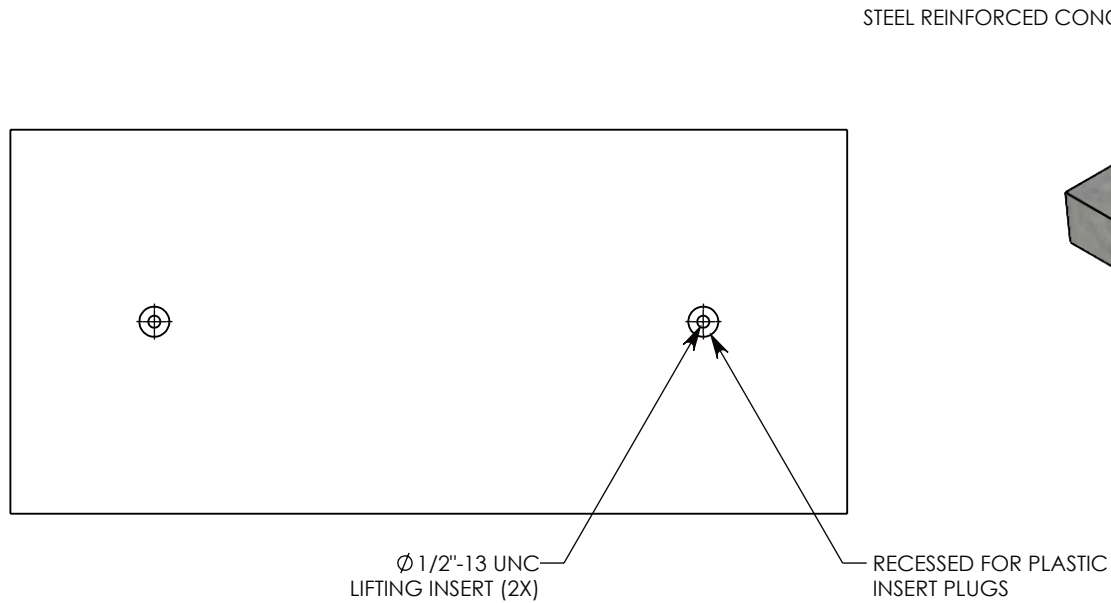
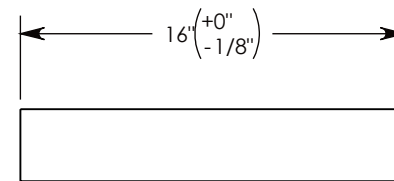
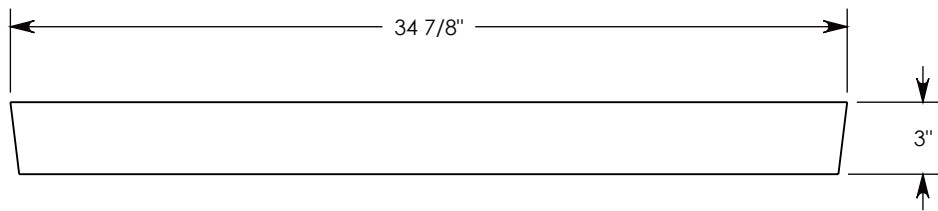

AASHTO H-20 RATED – 32,000 LB. SINGLE AXLE LOAD

DRAWN BY: ROBIN FLINT	
CREATED DATE: 8/22/2002	REVISION LEVEL: C
SAVED DATE: 2/9/2024	SAVED BY: scallahan
WEIGHT: 135 LBS.	MATERIAL: CONCRETE



CONCAST
 1010 NORTH STAR DRIVE
 P.O. BOX 69
 ZUMBROTA, MN 55992-0069

DESCRIPTION:		SHEET 1 OF 1
HEAVY TRAFFIC COVER		
DIMENSIONS ARE IN INCHES	CONTACT INFORMATION:	
TOLERANCES:	EMAIL: INFO@CONCASTINC.COM	
FRACTIONAL: ± 1/8" ANGULAR: ± 2°	PHONE: (507) 732-4095 FAX: (507) 732-4094	
PART NUMBER:		
8031HT3 16"		