

DETAIL B
SCALE 1 : 12

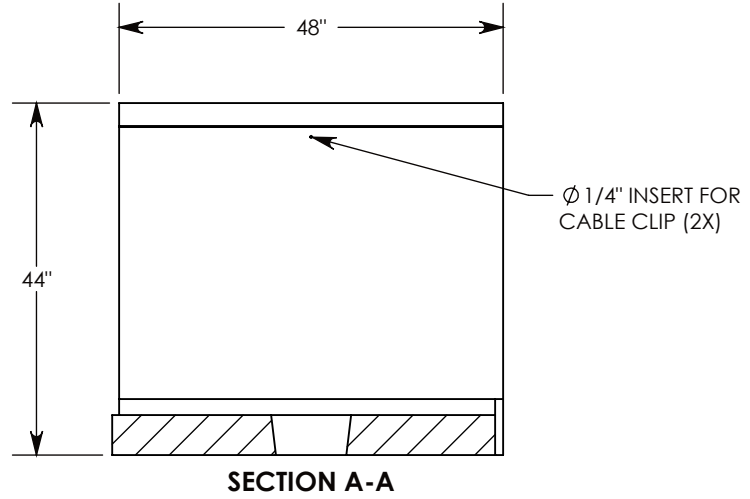
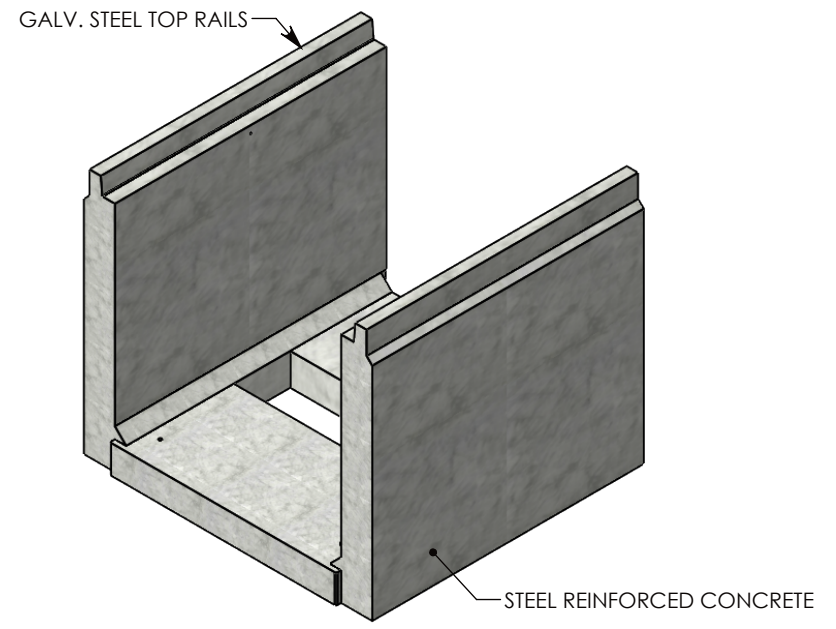
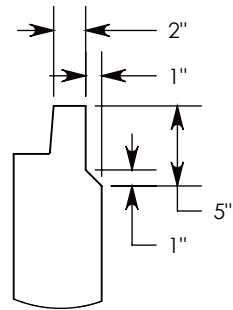

NOTE 1: FOR NON-STANDARD LENGTHS, THE CHANNEL WILL BE SOLID BOTTOM AND DESIGNATED WITH ITS CORRESPONDING LENGTH MEASUREMENT. IE: 804036HT3 32"

AASHTO H-20 RATED – 32,000 LB. SINGLE AXLE LOAD

DRAWN BY: MALACHI MLINAR	
CREATED DATE: 4/19/2018	REVISION LEVEL: A
SAVED DATE: 10/6/2020	SAVED BY: scallahan
WEIGHT: 2475 LBS.	MATERIAL: CONCRETE

1010 NORTH STAR DRIVE
P.O. BOX 69
ZUMBROTA, MN 55992-0069

DESCRIPTION: HEAVY TRAFFIC CHANNEL		SHEET 1 OF 1
DIMENSIONS ARE IN INCHES TOLERANCES: FRACTIONAL: ± 1/8" ANGULAR: ± 2°	CONTACT INFORMATION: EMAIL: INFO@CONCASTINC.COM PHONE: (507) 732-4095 FAX: (507) 732-4094	
PART NUMBER: 804036HT3		