

REV. A - SIC - 10/19/2020 - ADDED TOP RAIL REDUCTION FEATURE TO CHANGE TOP RAIL TO 2", WAS 3"; REPLACED RIGHT VIEW WITH SECTION A-A; ADDED DETAIL B

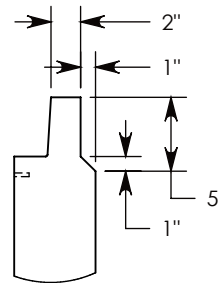

DETAIL B
SCALE 1 : 13

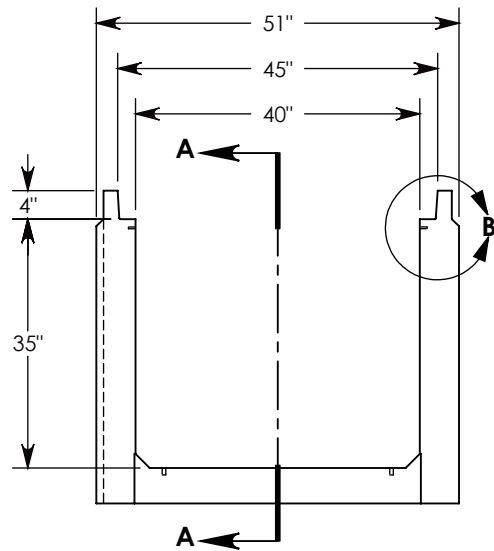
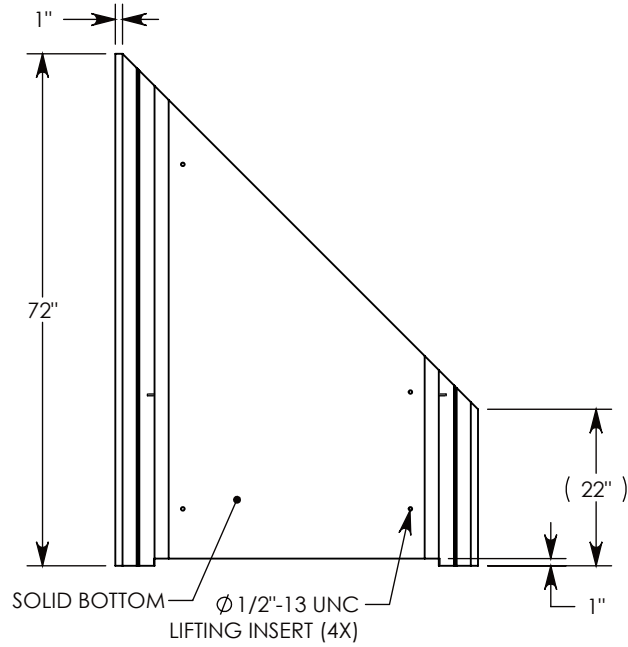
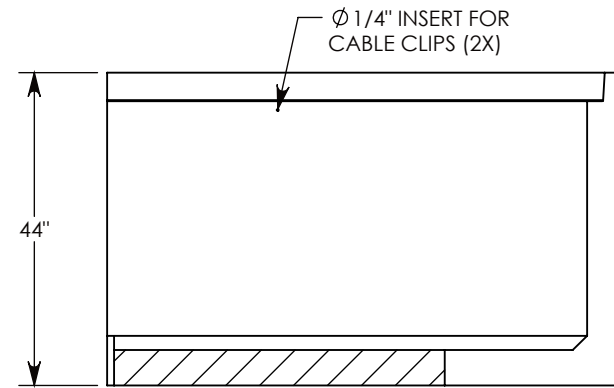
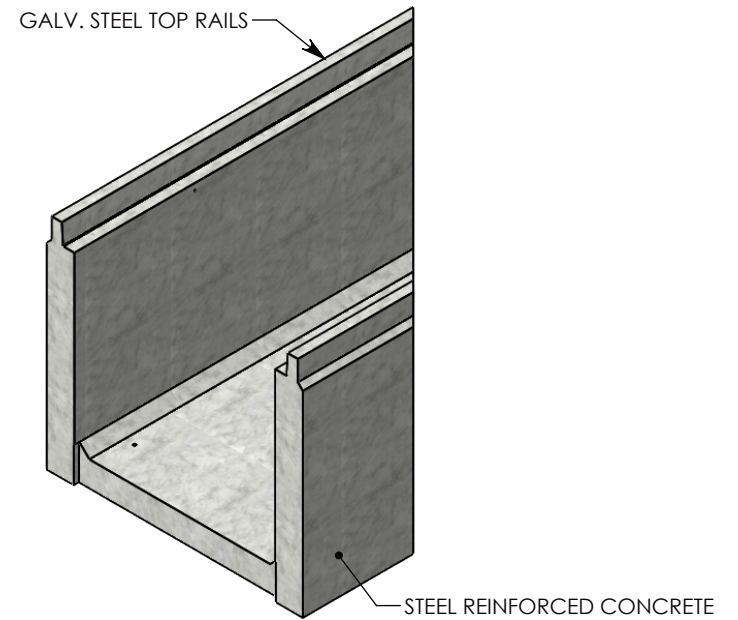

SECTION A-A

AASHTO H-20 RATED - 32,000 LB. SINGLE AXLE LOAD

DRAWN BY: SAMUEL CALLAHAN

CREATED DATE: 8/20/2019 **REVISION LEVEL: A**

SAVED DATE: 10/19/2020 **SAVED BY: scallahan**

WEIGHT: 2549 LBS. **MATERIAL: CONCRETE**



CONCAST
1010 NORTH STAR DRIVE
P.O. BOX 69
ZUMBROTA, MN 55992-0069

DESCRIPTION:

HEAVY TRAFFIC ANGLED CHANNEL

DIMENSIONS ARE IN INCHES
TOLERANCES:
FRACTIONAL: ± 1/8"
ANGULAR: ± 2°

CONTACT INFORMATION:
EMAIL: INFO@CONCASTINC.COM
PHONE: (507) 732-4095
FAX: (507) 732-4094

SHEET 1 OF 1

PART NUMBER:

804036HT4 45R