

FLEXIBLE SEAL RING

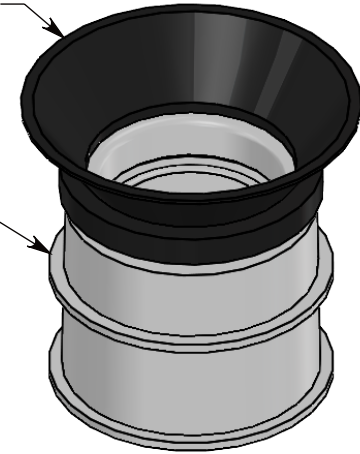

TERMINATOR COLOR MAY VARY
GRAY SHOWN FOR VISIBILITY

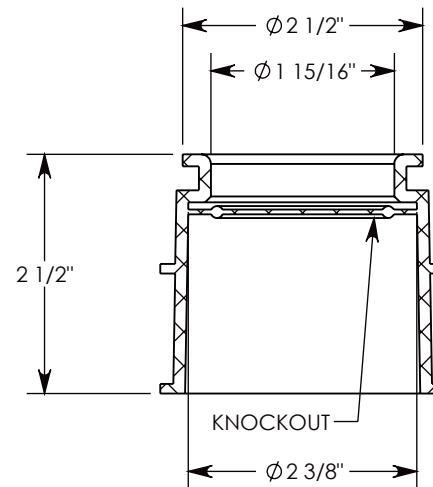
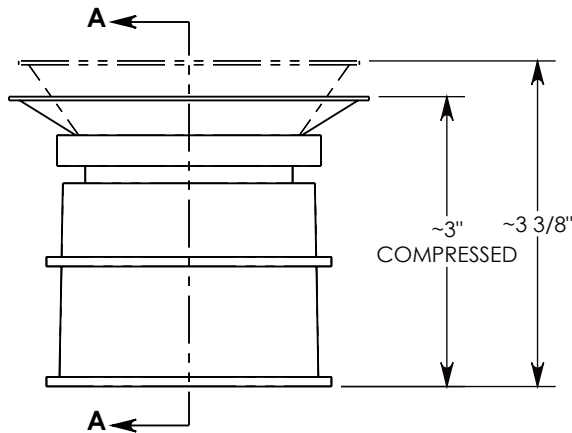

SECTION A-A
SEAL RING HIDDEN

VENDOR: LEVIAT/MEADOWBURKE
VENDOR NO: T2000

NOTE 1: FOR USE WITH 2" ID SCHEDULE 40 PVC CONDUIT.

NOTE 2: ACTUAL PRODUCT APPEARANCE MAY VARY. DIMENSIONS SHOWN ARE APPROXIMATE

DRAWN BY: **SAMUEL CALLAHAN**

CREATED DATE: **11/20/2023** REVISION LEVEL: **0**

SAVED DATE: **11/20/2023** SAVED BY: **scallahan**

WEIGHT: **0.2 LBS.** MATERIAL: **PLASTIC**

CONCAST
1010 NORTH STAR DRIVE
P.O. BOX 69
ZUMBROTA, MN 55992-0069

DESCRIPTION:
2" DUCT TERMINATOR

DIMENSIONS ARE IN INCHES
TOLERANCES:
FRACTIONAL: $\pm 1/8"$
ANGULAR: $\pm 2^\circ$

CONTACT INFORMATION:
EMAIL: INFO@CONCASTINC.COM
PHONE: (507) 732-4095
FAX: (507) 732-4094

SHEET 1 OF 1

PART NUMBER:
CD-23