

- 1/2-13 UNC X 1" LG HEX HD BOLT  
P/N: HHB.5-1 (2X)
- 4" HOLD-DOWN CLAMP  
P/N: HDC-1 (2X)
- 1/2-13 UNC SPRING NUT  
P/N: USN-.5 (2X)
- FIBERCRETE BOX PAD  
P/N: FC-42-48-20-2626 (4) (2X)

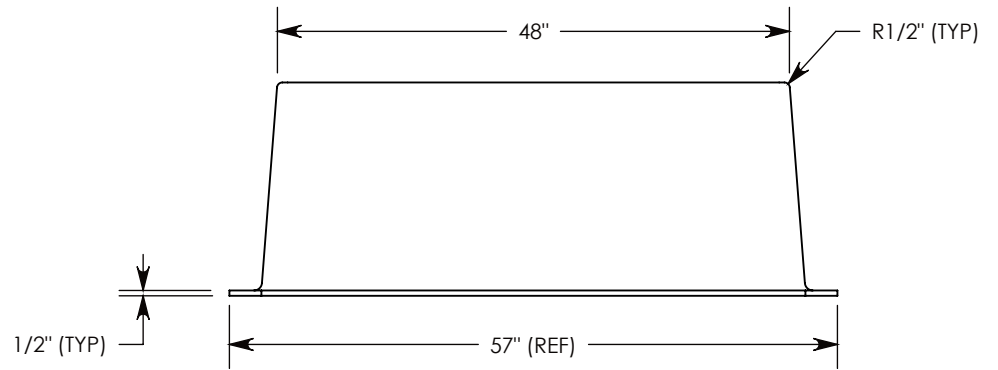
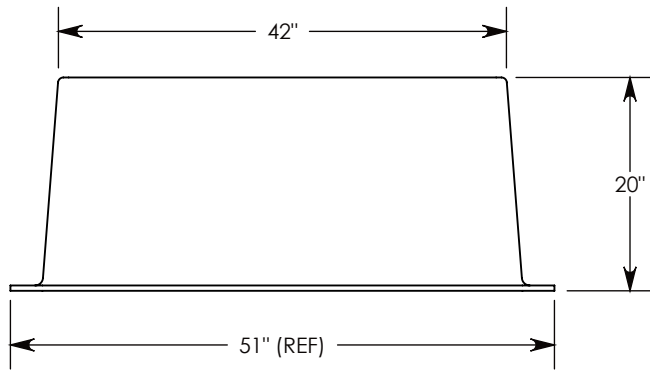
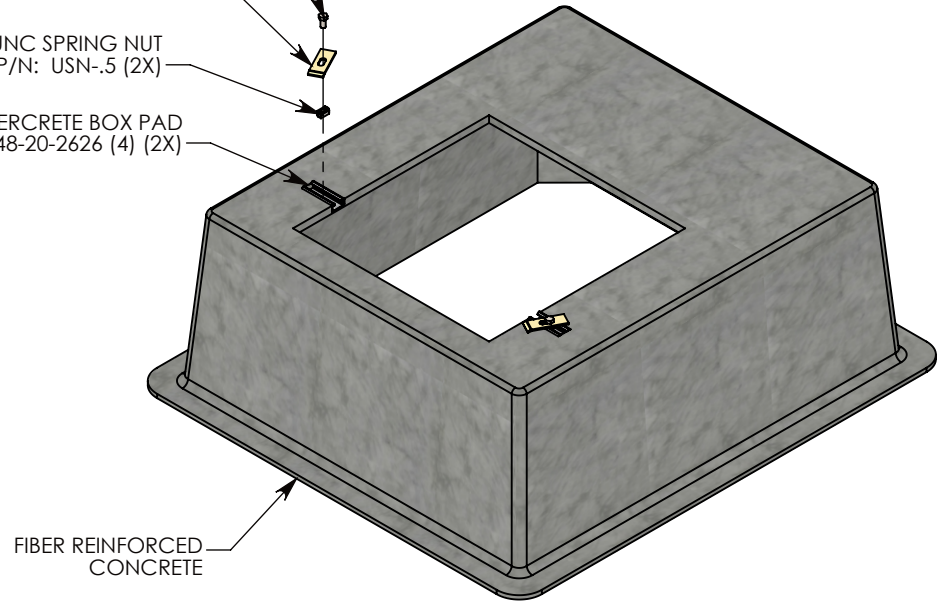

**DRAWN BY: ROBIN FLINT**

**DATE: 5/30/2016**

**REVISION LEVEL: 0**

**WEIGHT:**

**303 LBS.**

**MATERIAL:**

**FIBERCRETE**



1010 NORTH STAR DRIVE  
P.O. BOX 69  
ZUMBROTA, MN 55992-0069

**DESCRIPTION:**

**FIBERCRETE BOX PAD**

DIMENSIONS ARE IN INCHES  
TOLERANCES:  
FRACTIONAL:  $\pm 1/8"$   
ANGULAR:  $\pm 2^\circ$

CONTACT INFORMATION:  
EMAIL: [INFO@CONCASTINC.COM](mailto:INFO@CONCASTINC.COM)  
PHONE: (507) 732-4095  
FAX: (507) 732-4094

SHEET 1 OF 1

**PART NUMBER:**

**FC-42-48-20-2626 (4)**