

FIBER REINFORCED CONCRETE

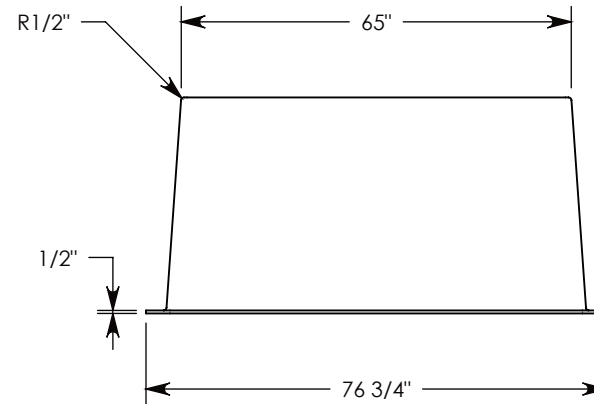
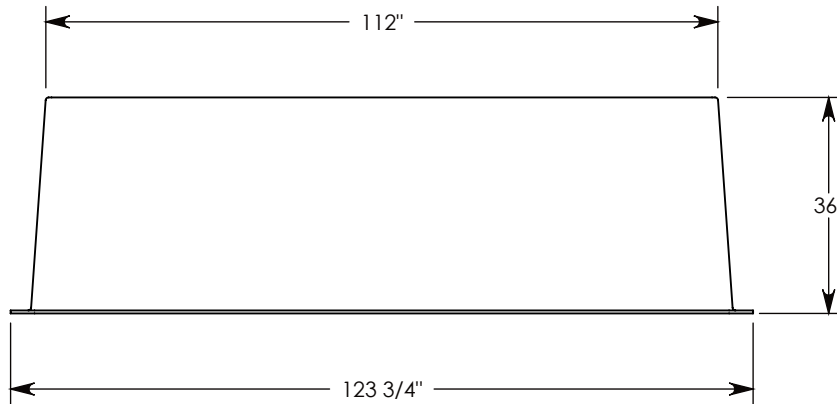
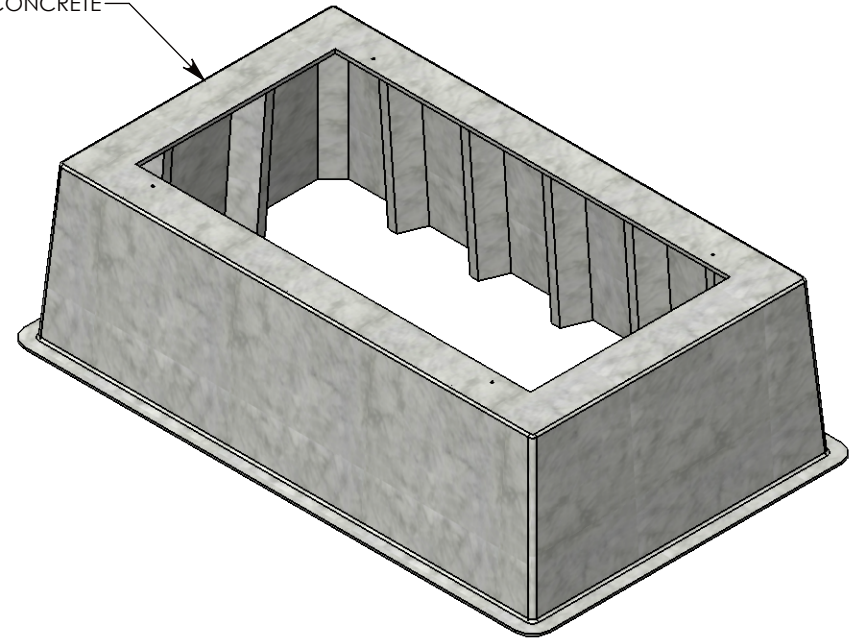

NOTE 1: IF SPECIFIC INSERTS OR MOUNTING HARDWARE ARE REQUIRED, PLEASE SPECIFY WHEN ORDERING.

DRAWN BY: JESSE GUTTING

DATE: 9/3/2019

REVISION LEVEL: 0

WEIGHT:

998 LBS.

MATERIAL:

FIBERCRETE FC



DESCRIPTION:

FIBERCRETE BOX PAD

DIMENSIONS ARE IN INCHES
 TOLERANCES:
 FRACTIONAL: ± 1/8"
 ANGULAR: ± 2°

CONTACT INFORMATION:
 EMAIL: INFO@CONCASTINC.COM
 PHONE: (507) 732-4095
 FAX: (507) 732-4094

SHEET 1 OF 1

PART NUMBER:

FC-65-112-36-4793C