

FIBERCRETE[®]

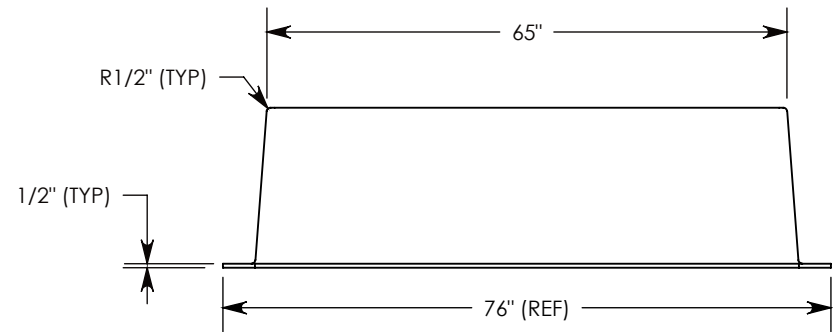
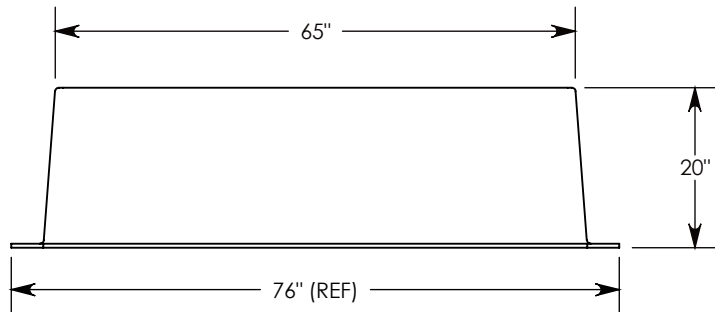
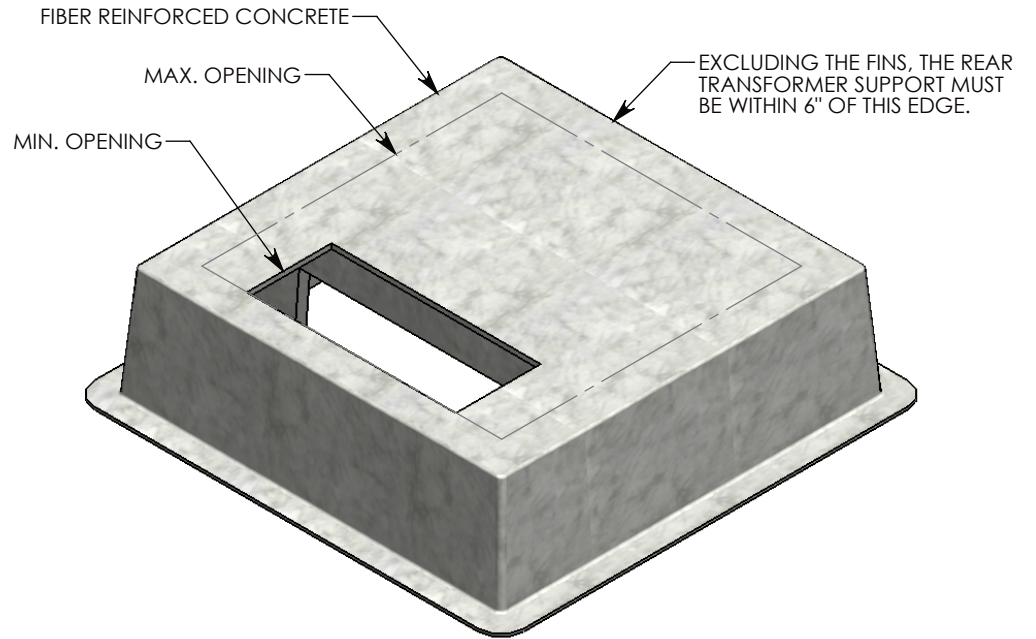
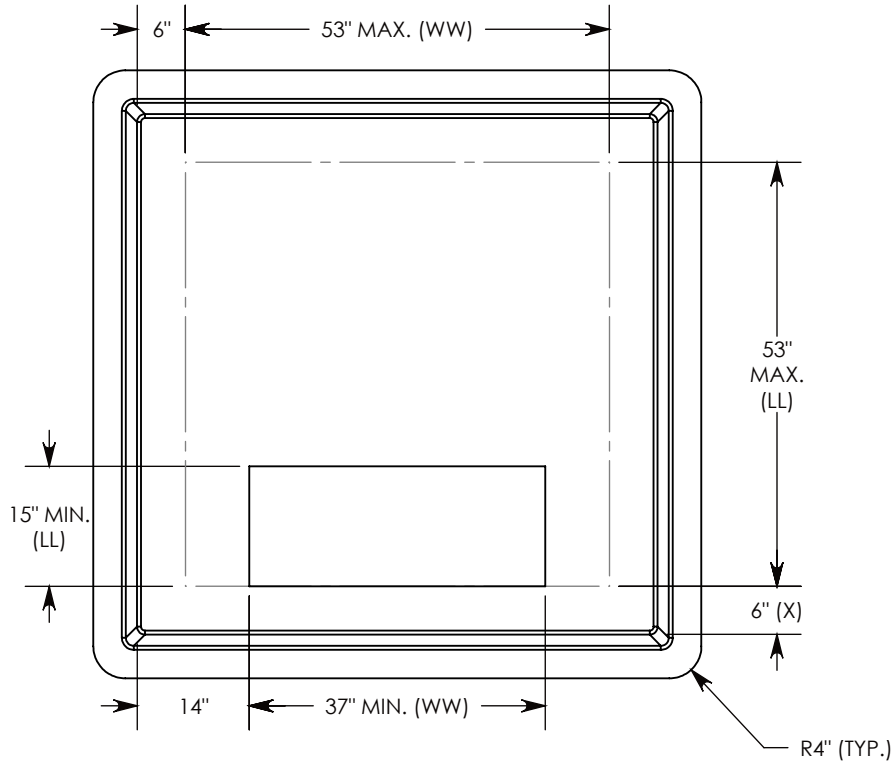

Ø 1/2"-13 UNC LIFTING INSERTS WILL BE CAST INTO BOX PAD
 IF SPECIFIC INSERTS OR MOUNTING HARDWARE ARE REQUIRED, PLEASE SPECIFY WHEN ORDERING.
 PART NUMBER IS BASED ON OPENING SIZE. IE: THE SMALLEST OPENING PAD IS P/N: FC-65-65-20-1537(6)
 THE LARGEST OPENING PAD IS P/N: FC-65-65-20-5353

DRAWN BY: ROBIN FLINT

DATE: 3/6/2012

REVISION LEVEL: 0

WEIGHT:

695 LBS.

MATERIAL:

FIBERCRETE FC



CONCAST
 1010 NORTH STAR DRIVE
 P.O. BOX 69
 ZUMBROTA, MN 55992-0069

DESCRIPTION:

FIBERCRETE BOX PAD

DIMENSIONS ARE IN INCHES
 TOLERANCES:
 FRACTIONAL: ± 1/8"
 ANGULAR: ± 2°

CONTACT INFORMATION:
 EMAIL: INFO@CONCASTINC.COM
 PHONE: (507) 732-4095
 FAX: (507) 732-4094

SHEET 1 OF 1

PART NUMBER:

FC-65-65-20-LLWW (X)