

REVISION B - RLF - 6/7/16 - 1" INTERLOCK RELIEF WAS A 7/8" PROTRUSION.

FIBERCRETE[®]
TRENCH SYSTEM

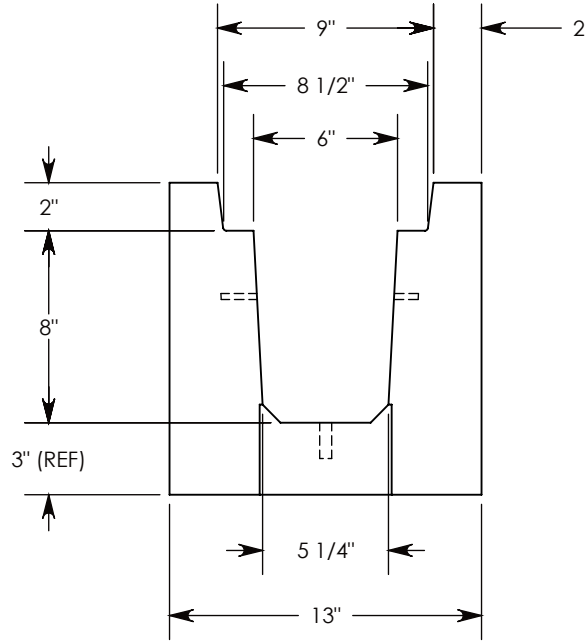

DETAIL A
SCALE 1 : 8

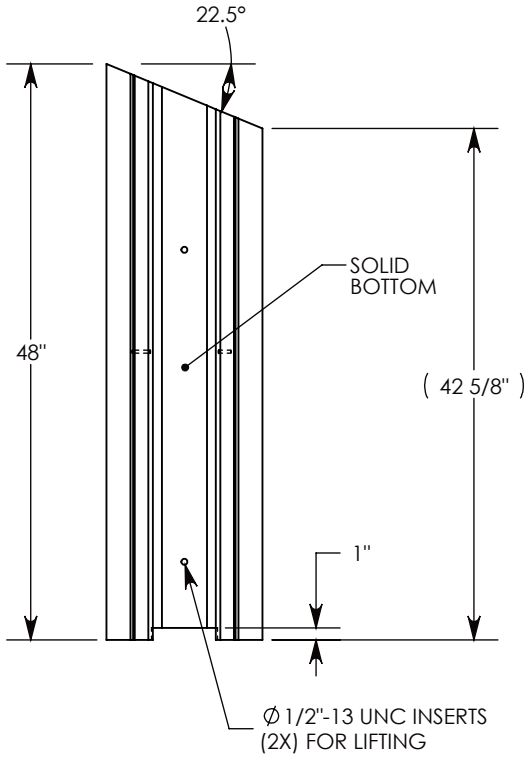
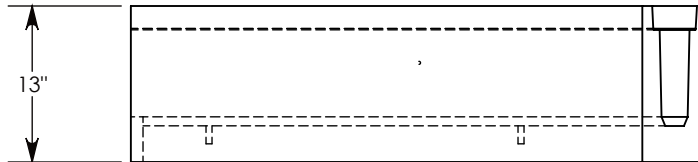
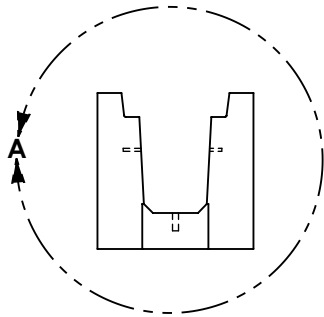
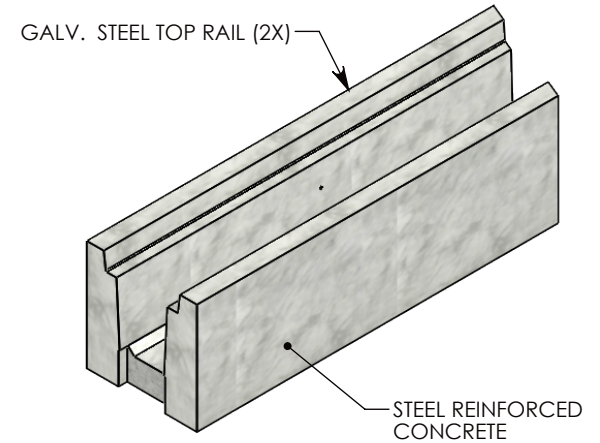

NOTE 1: MM#30032857

H-20 RATED - 32,000 LB. PER AXLE LOAD

DRAWN BY: ROBIN FLINT

DATE: 7/15/2017

REVISION LEVEL: B

WEIGHT:

397 LBS.

MATERIAL:

CONCRETE

CONCAST
 1010 NORTH STAR DRIVE
 P.O. BOX 69
 ZUMBROTA, MN 55992-0069

DESCRIPTION:

HEAVY TRAFFIC CHANNEL - 22.5 ANGLE

DIMENSIONS ARE IN INCHES
 TOLERANCES:
 FRACTIONAL: ± 1/8"
 ANGULAR: ± 2°

CONTACT INFORMATION:
 EMAIL: INFO@CONCASTINC.COM
 PHONE: (507) 732-4095
 FAX: (507) 732-4094

SHEET 1 OF 1

PART NUMBER:

HT0608 22.5R