

REV. A - RLF - 6/7/2016 - 1" INTERLOCK RELIEF WAS A 7/8" PROTRUSION.
 REV. B - SIC - 8/21/2019 - UPDATED ANNOTATIONS, DIMENSIONS, AND VIEWS; ADDED TWO 1/2" LIFTING INSERTS; UPDATED LIFTING INSERT LAYOUT

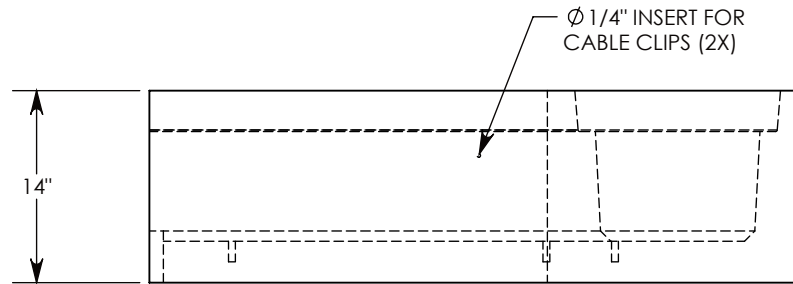
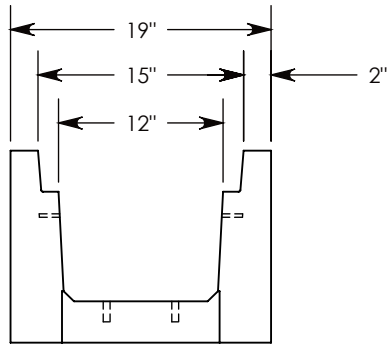
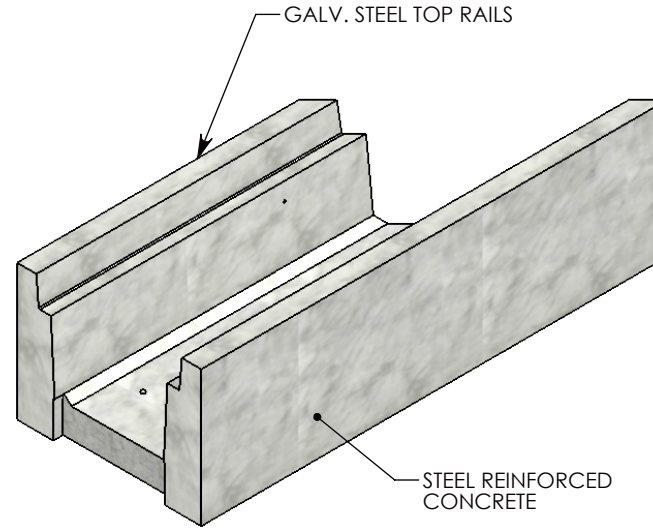
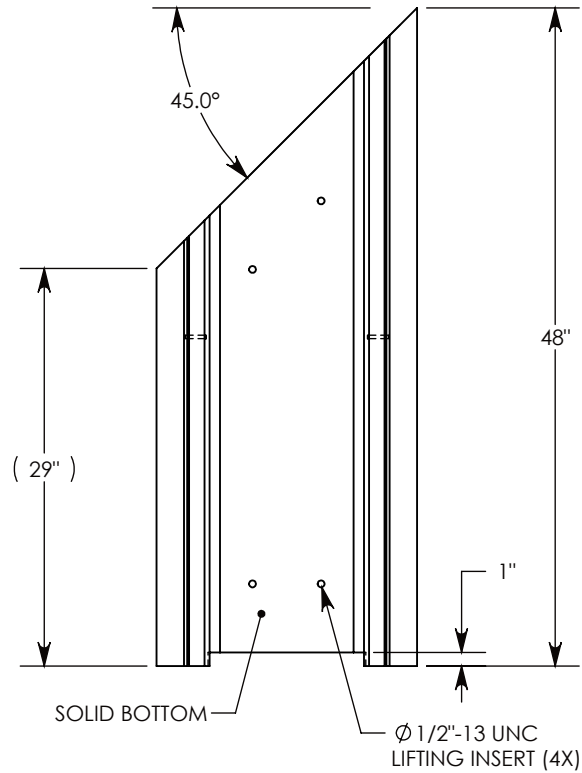

AASHTO H-20 RATED - 32,000 LB. SINGLE AXLE LOAD

DRAWN BY: ROBIN FLINT

DATE: 8/21/2019

REVISION LEVEL: B

WEIGHT:

406 LBS.

MATERIAL:

CONCRETE

CONCAST
 1010 NORTH STAR DRIVE
 P.O. BOX 69
 ZUMBROTA, MN 55992-0069

DESCRIPTION:
HEAVY TRAFFIC CHANNEL - 45 ANGLE

DIMENSIONS ARE IN INCHES
 TOLERANCES:
 FRACTIONAL: ± 1/8"
 ANGULAR: ± 2°

CONTACT INFORMATION:
 EMAIL: INFO@CONCASTINC.COM
 PHONE: (507) 732-4095
 FAX: (507) 732-4094

SHEET 1 OF 1

PART NUMBER:
HT1208 45L