

REV. A - RLF - 6/7/2016 - 1" INTERLOCK RELIEF WAS A 7/8" PROTRUSION.  
 REV. B - SIC - 10/9/2019 - 1/2"-13 UNC LIFTING INSERTS QTY: 4, WAS QTY: 2; REMOVED NOTE 1; ADDED CABLE CLIP NOTATION

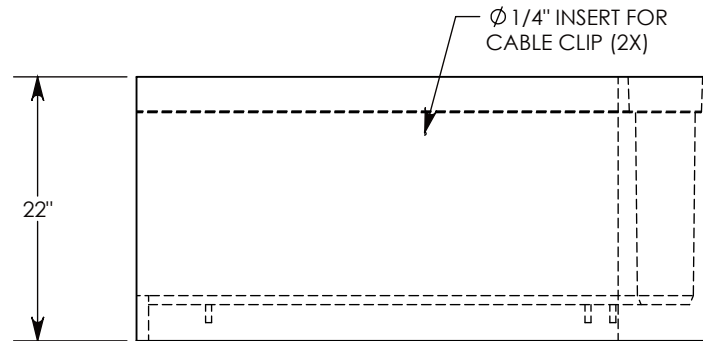

AASHTO H-40 RATED - 64,000 LB. SINGLE AXLE LOAD  
 MINIMUM ALLOWABLE SOIL BEARING PRESSURE - X,XXX PSF

<b>DRAWN BY:</b> ROBIN FLINT	
<b>CREATED DATE:</b> 7/28/2015	<b>REVISION LEVEL:</b> B
<b>SAVED DATE:</b> 5/29/2020	<b>SAVED BY:</b> mmlinar
<b>WEIGHT:</b> 678 LBS.	<b>MATERIAL:</b> CONCRETE

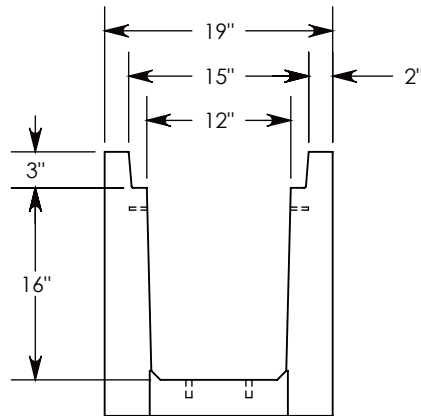
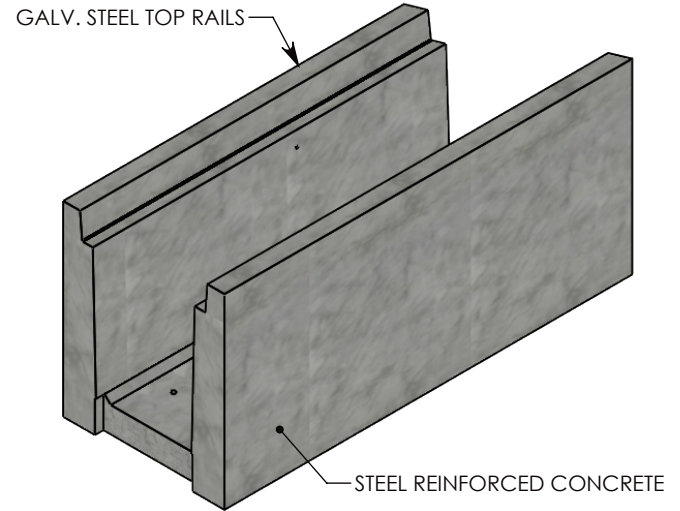
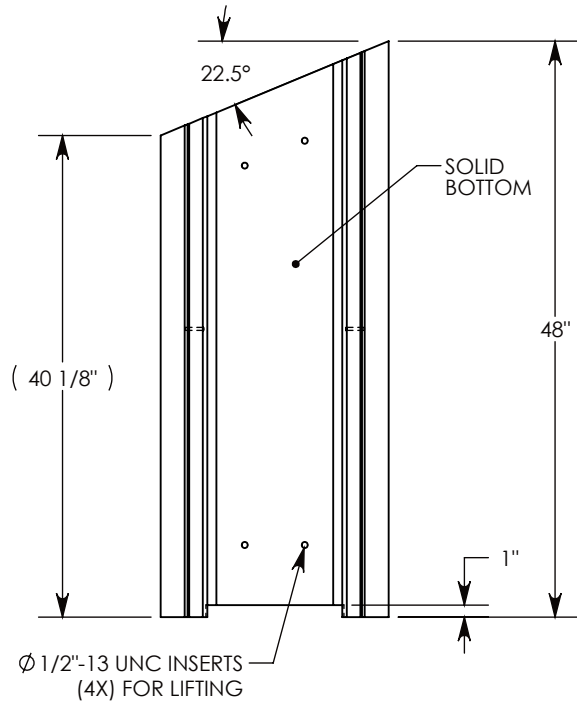

1010 NORTH STAR DRIVE  
 P.O. BOX 69  
 ZUMBROTA, MN 55992-0069

<b>DESCRIPTION:</b> <b>HEAVY TRAFFIC CHANNEL - 22.5 ANGLE</b>		SHEET 1 OF 1
DIMENSIONS ARE IN INCHES TOLERANCES: FRACTIONAL: ± 1/8" ANGULAR: ± 2°	CONTACT INFORMATION: EMAIL: INFO@CONCASTINC.COM PHONE: (507) 732-4095 FAX: (507) 732-4094	
<b>PART NUMBER:</b> HT1216 22.5L		