

REV. A - RLF - 6/7/2016 - 1" INTERLOCK RELIEF WAS A 7/8" PROTRUSION.

REV. B - SIC - 10/9/2019 - 1/2"-13 UNC LIFTING INSERTS QTY: 4, WAS QTY: 2; REMOVED NOTE 1; ADDED CABLE CLIP NOTATION

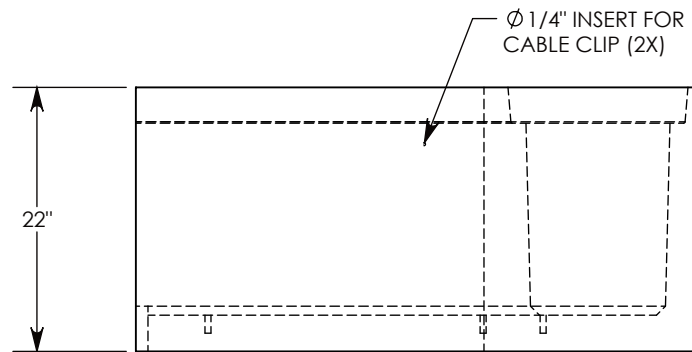
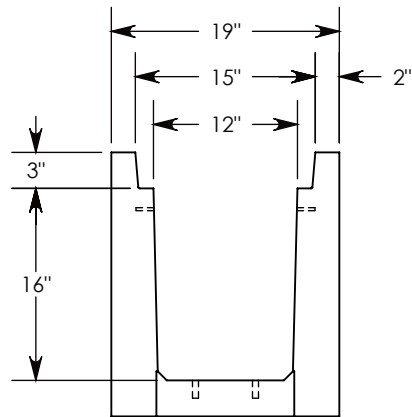
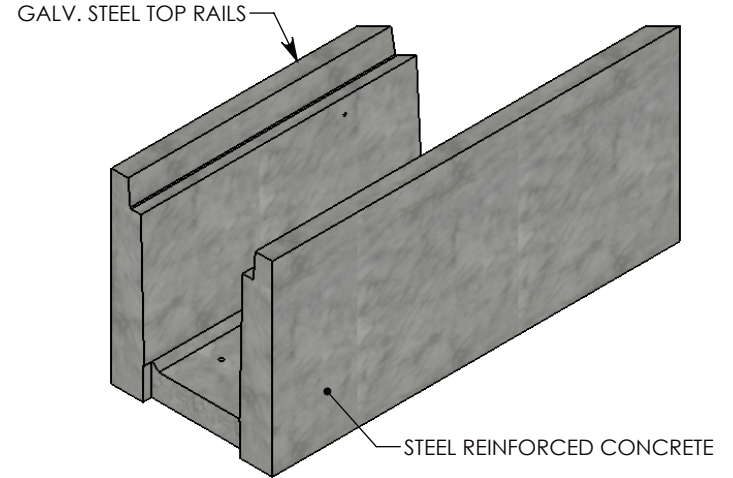
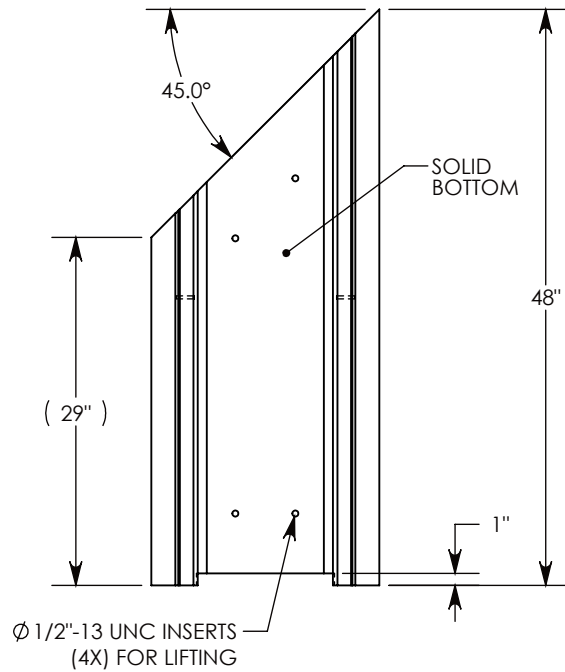

AASHTO H-40 RATED - 64,000 LB. SINGLE AXLE LOAD
 MINIMUM ALLOWABLE SOIL BEARING PRESSURE - X,XXX PSF

DRAWN BY: ROBIN FLINT

CREATED DATE: 7/28/2015 **REVISION LEVEL:** B

SAVED DATE: 5/29/2020 **SAVED BY:** mmlinar

WEIGHT: 592 LBS. **MATERIAL:** CONCRETE

CONCAST
 1010 NORTH STAR DRIVE
 P.O. BOX 69
 ZUMBROTA, MN 55992-0069

DESCRIPTION:
HEAVY TRAFFIC CHANNEL - 45 ANGLE

DIMENSIONS ARE IN INCHES
 TOLERANCES:
 FRACTIONAL: ± 1/8"
 ANGULAR: ± 2°

CONTACT INFORMATION:
 EMAIL: INFO@CONCASTINC.COM
 PHONE: (507) 732-4095
 FAX: (507) 732-4094

SHEET 1 OF 1

PART NUMBER:
HT1216 45L