

DETAIL B
SCALE 1 : 15
HIDDEN LINES REMOVED

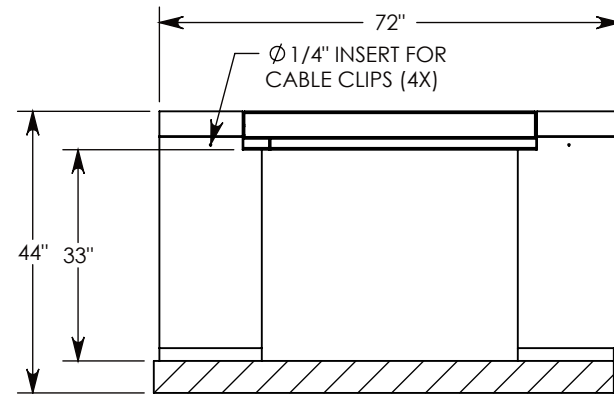
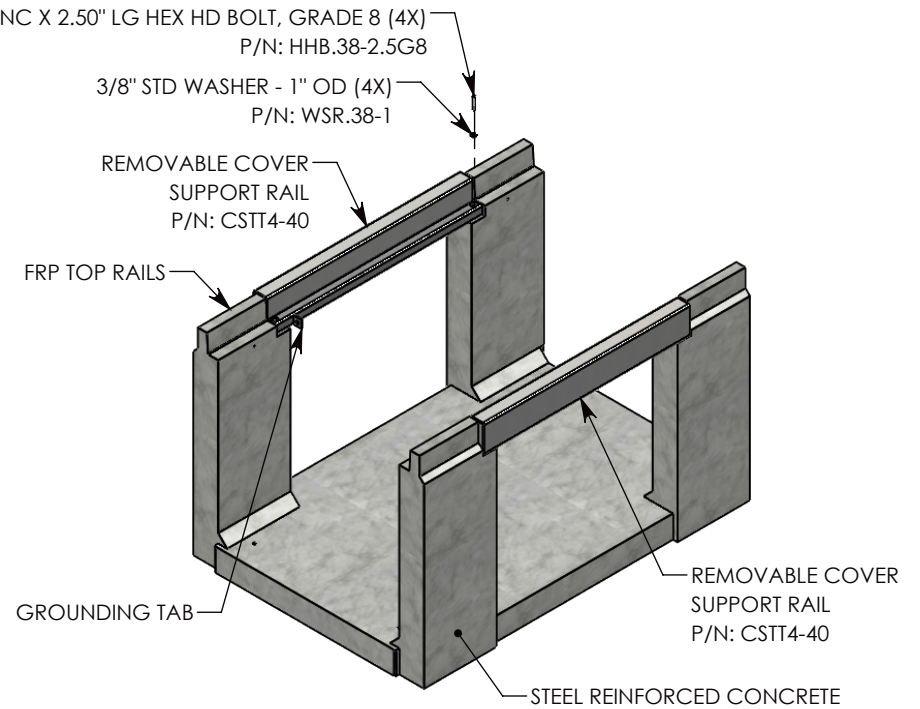

SECTION A-A

AASHTO H-20 RATED - 32,000 LB. SINGLE AXLE LOAD

DRAWN BY: SAMUEL CALLAHAN

CREATED DATE: 8/28/2019 REVISION LEVEL: A

SAVED DATE: 10/21/2020 SAVED BY: scallahan

WEIGHT: 2629 LBS. MATERIAL: NOTED

1010 NORTH STAR DRIVE
 P.O. BOX 69
 ZUMBROTA, MN 55992-0069

DESCRIPTION:
HEAVY TRAFFIC UNIVERSAL CHANNEL

DIMENSIONS ARE IN INCHES
 TOLERANCES:
 FRACTIONAL: $\pm 1/8"$
 ANGULAR: $\pm 2^\circ$

CONTACT INFORMATION:
 EMAIL: INFO@CONCASTINC.COM
 PHONE: (507) 732-4095
 FAX: (507) 732-4094

SHEET 1 OF 1

PART NUMBER:
HT4FU4036 (40X40)