

DETAIL A
SCALE 1 : 8

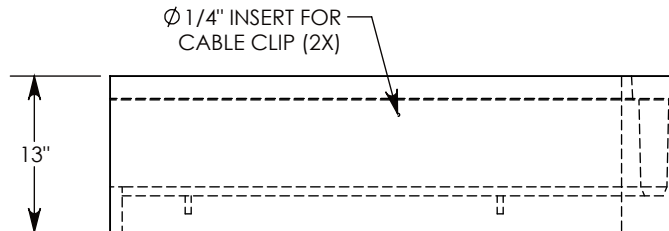

AASHTO H-40 RATED – 64,000 LB. SINGLE AXLE LOAD
MINIMUM ALLOWABLE SOIL BEARING PRESSURE – 5,500 PSF

DRAWN BY: ROBIN FLINT	
CREATED DATE: 7/28/2015	REVISION LEVEL: C
SAVED DATE: 3/27/2020	SAVED BY: scallahan
WEIGHT: 397 LBS.	MATERIAL: CONCRETE

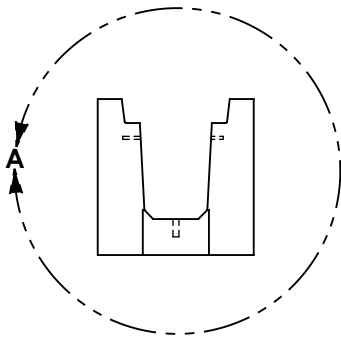
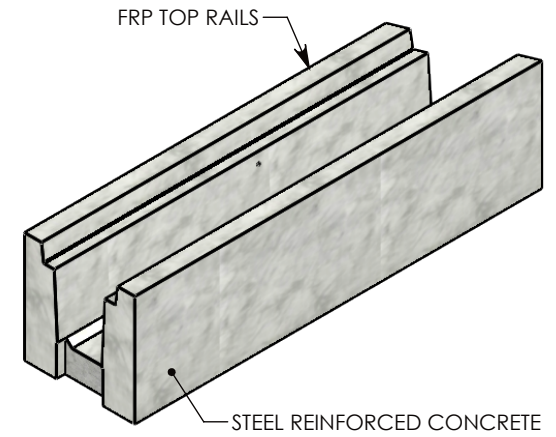

1010 NORTH STAR DRIVE
P.O. BOX 69
ZUMBROTA, MN 55992-0069

DESCRIPTION: HEAVY TRAFFIC CHANNEL - 22.5 ANGLE		SHEET 1 OF 1
DIMENSIONS ARE IN INCHES TOLERANCES: FRACTIONAL: ± 1/8" ANGULAR: ± 2°	CONTACT INFORMATION: EMAIL: INFO@CONCASTINC.COM PHONE: (507) 732-4095 FAX: (507) 732-4094	
PART NUMBER: HTF0608 22.5L		