

DETAIL B  
SCALE 1 : 12

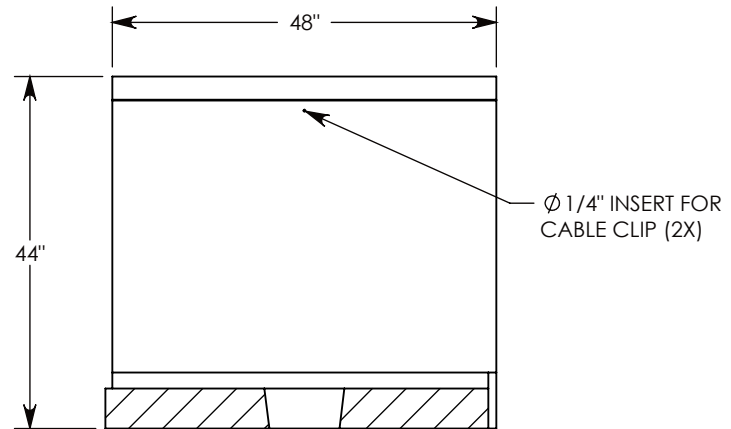
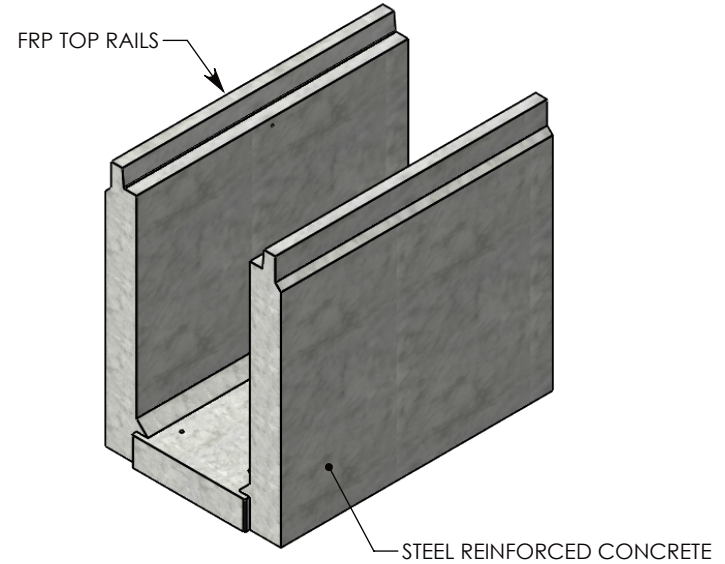

SECTION A-A

NOTE 1: FOR NON-STANDARD LENGTHS THE CHANNEL WILL BE SOLID BOTTOM AND DESIGNATED WITH ITS CORRESPONDING LENGTH MEASUREMENT. IE: HTF2036 36"

AASHTO H-20 RATED – 32,000 LB. SINGLE AXLE LOAD

**DRAWN BY: SAMUEL CALLAHAN**

**CREATED DATE: 8/13/2019** **REVISION LEVEL: A**

**SAVED DATE: 10/8/2020** **SAVED BY: scallahan**

**WEIGHT: 2159 LBS.** **MATERIAL: CONCRETE**

**CONCAST**  
1010 NORTH STAR DRIVE  
P.O. BOX 69  
ZUMBROTA, MN 55992-0069

**DESCRIPTION:**  
**HEAVY TRAFFIC CHANNEL**

DIMENSIONS ARE IN INCHES  
TOLERANCES:  
FRACTIONAL: ± 1/8"  
ANGULAR: ± 2°

CONTACT INFORMATION:  
EMAIL: INFO@CONCASTINC.COM  
PHONE: (507) 732-4095  
FAX: (507) 732-4094

SHEET 1 OF 1

**PART NUMBER:**  
**HTF2036 48"**