

DETAIL B  
SCALE 1 : 15

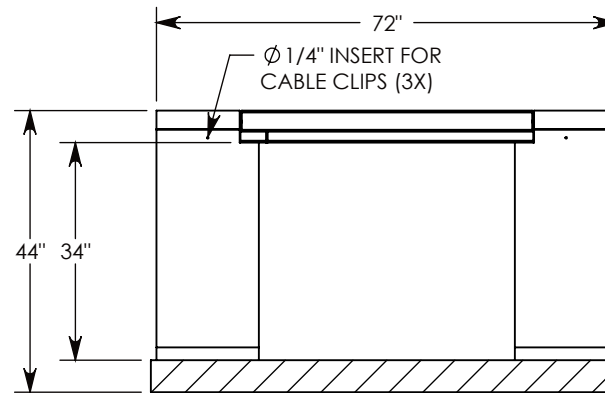

SECTION A-A

AASHTO H-20 RATED - 32,000 LB. SINGLE AXLE LOAD

**DRAWN BY:** SAMUEL CALLAHAN

**CREATED DATE:** 8/28/2019 **REVISION LEVEL:** A

**SAVED DATE:** 10/14/2020 **SAVED BY:** scallahan

**WEIGHT:** 3276 LBS. **MATERIAL:** NOTED

  
 1010 NORTH STAR DRIVE  
 P.O. BOX 69  
 ZUMBROTA, MN 55992-0069

**DESCRIPTION:**  
**HEAVY TRAFFIC UNIVERSAL CHANNEL**

DIMENSIONS ARE IN INCHES  
 TOLERANCES:  
 FRACTIONAL:  $\pm 1/8"$   
 ANGULAR:  $\pm 2^\circ$

CONTACT INFORMATION:  
 EMAIL: INFO@CONCASTINC.COM  
 PHONE: (507) 732-4095  
 FAX: (507) 732-4094

SHEET 1 OF 1

**PART NUMBER:**  
**HTFU4036 (0X40)**