

**FIBERCRETE<sup>®</sup>**  
**TRENCH**  
**SYSTEM**

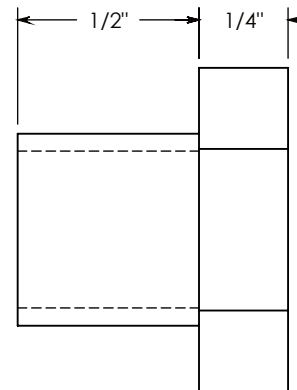
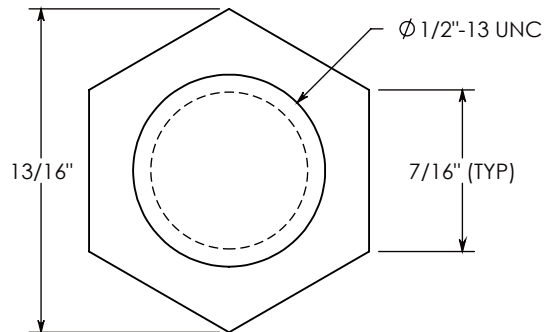
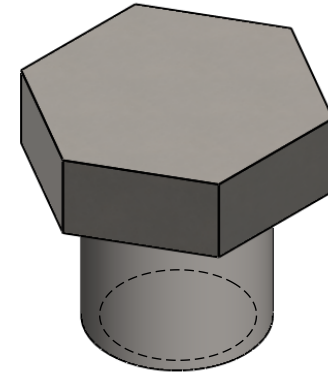

**DRAWN BY: COLIN HORTOP**

**DATE: 10/18/2011**

**REVISION LEVEL: 0**

**WEIGHT:**

**LBS.**

**MATERIAL:**

**STAINLESS STEEL**



1010 NORTH STAR DRIVE  
 P.O. BOX 69  
 ZUMBROTA, MN 55992-0069

**DESCRIPTION:**

**INSERT PLUG BOLT**

DIMENSIONS ARE IN INCHES  
 TOLERANCES:  
 FRACTIONAL:  $\pm 1/8"$   
 ANGULAR:  $\pm 2^\circ$

CONTACT INFORMATION:  
 EMAIL: [INFO@CONCASTINC.COM](mailto:INFO@CONCASTINC.COM)  
 PHONE: (507) 732-4095  
 FAX: (507) 732-4094

SHEET 1 OF 1

**PART NUMBER:**

**IPB.5**